

OPERATING MANUAL

RISH CON - CA/CV

TRUE RMS CURRENT OR VOLTAGE TRANSDUCER



15001077_Rev._C - 02/2013

Operating Instructions

Contents

1. Read first and then	3
2. Brief Description	3
3. Product Features	3
4. Overview of the Parts	4
5. Scope of supply	5
6. Technical Data	5
7. Mounting	9
8. Electrical Connections	11
9. Commissioning	13
10. Dimensional Drawings	13

1. Read first and then

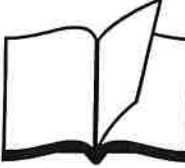
	The proper and safe operation of the device assumes that the Operating Instructions are read and the safety warnings given in the various sections Mounting, Electrical Connections, Commissioning are observed.
	All operations concerning installation, electrical connections and commissioning, must be carried out by qualified, skilled personnel, and national regulations for the prevention of accidents must be observed.

2. Brief description

The Transducer is used to convert AC Current or Voltage input into an proportional DC Current or Voltage output signal. Output signal generated is proportional to the root mean square value of the input Current or Voltage.

The transducer output is galvanically isolated from the input signal and auxiliary supply.

3. Product Features

Measuring Input :

AC Current/ Voltage input signal , sine wave or distorted waveform.

Auxiliary Power Supply (H):

Accept any input between 40 V-300 V AC/DC.

Auxiliary Power Supply (L):

Accept any input between 24 V-60 V AC/DC $\pm 10\%$.

Analog Output :

Isolated analog output, which can be Voltage or Current.

Accuracy:

Output signal accuracy class 0.2 as per International Standard **IEC/EN 60688**.

LED Indication:

LED indication for power ON.

4. Overview of the parts

Figure 1 shows those parts of the device which are used for mounting, electrical connections and other operations described in the Operating instructions.

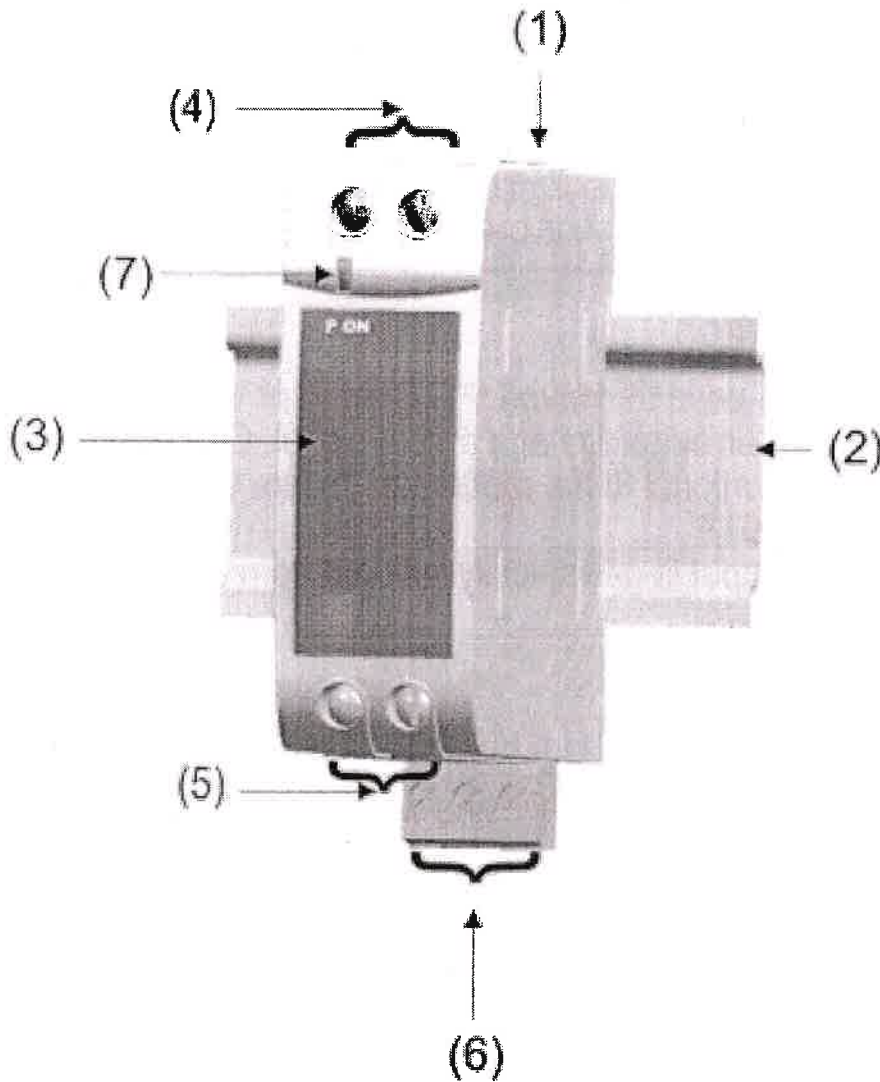

Fig. 1: Overview of the Transducer parts

- (1) Fixing Bracket
- (2) Top-hat rail
- (3) Front sticker
- (4) Input Terminals
- (5) Output Terminals
- (6) Auxiliary Supply Terminals
- (7) Green LED for Power ON indication.

5. Scope of Supply

The set of the Transducer is consist of :

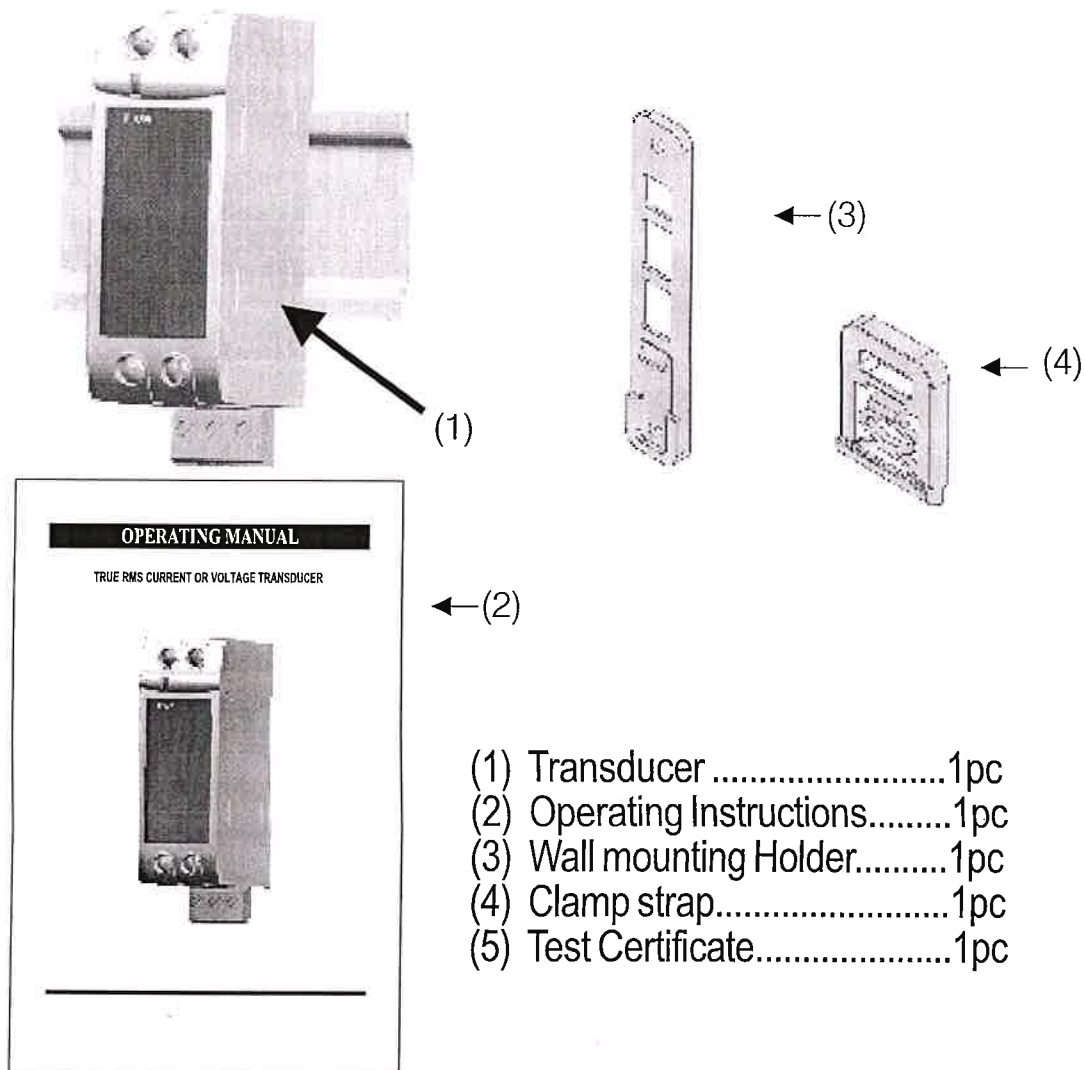

Fig. 2: Transducer Set

6. Technical Data

Measuring Input X:

Voltage Transducer :

Final value of Nominal input

$$63.5V \leq U_N \leq 500 V.$$

Voltage U_N (X2,AC RMS)

Nominal Frequency F_N

50 or 60 Hz.

Nominal input Voltage burden

< 0.6 VA at U_N .

Overload Capacity:

1.2 * U_N continuously,
 2 * U_N for 1 second, repeated
 10 times at 10 second intervals.

Current Transducer :

Final value of Nominal input Current I_N (X2,ACRMS)	1 A or 5 A.
Nominal Frequency F_N	50 or 60 Hz.
Nominal input Current burden	< 0.2VA at I_N .
Overload Capacity:	1.2 * I_N continuously, 10 * I_N for 3 second, repeated 5 times at 5 minute intervals, 20 * I_N for 3 second, repeated 5 times at 5 minute intervals, 50 * I_N for 1 second.

Measuring Output Y:

Output type	Load independent DC Voltage/Current.
Load independent DC output (Y2)	0...10mA,0...20mA,2...10mA, 4...20mA,0...5V or 0...10V.
Output burden with DC current output Signal	$0 \leq R \leq 15 \text{ V/Y2}$
Output burden with DC voltage output Signal	$Y2/(2 \text{ mA}) \leq R \leq \infty$
Current limit under overload $R=0$	$\leq 1.6*Y2$ with Current output. $\leq 25 \text{ mA}$ with Voltage output.
Voltage limit under $R = \infty$	$\leq 1.6*Y2$ with Voltage output. $\leq 25 \text{ V}$ with Current output.
Residual Ripple in Output signal	$\leq 1\%$ pk-pk.
Response Time	< 250 ms.

Auxiliary Supply H:

Rated operating voltage(H)	40 to 300 V AC/DC
Rated operating range of frequency(H)	45...50...60...65 Hz
Power consumption (H)	< 4 VA
Rated operating voltage(L)	24 to 60 V AC/DC $\pm 10\%$
Rated operating range of frequency(L)	40...400 Hz
Power consumption (L)	< 3 VA

Accuracy:(Acc. to IEC/EN 60 688)

Reference Value

Output end Value Y2

(Voltage or Current)

class0.2

Accuracy

Reference conditions for Accuracy :

Ambient temperature

23°C +/- 1°C

Pre-conditioning

30 min acc. to IEC/EN 60 688

Input Variable

Rated Voltage Range

/Rated Current Range.

Input waveform

Sinusoidal, Form Factor 1.1107

Input signal frequency

50....60Hz

Auxiliary supply voltage

Rated Value $\pm 1\%$

Auxiliary supply frequency

Rated Value $\pm 1\%$

Output Load

$R_N = 7.5 \text{ V} / Y2 \pm 1\%$ With DC current output signal.

$R_N = Y2 / 1 \text{ mA} \pm 1\%$ With DC voltage output signal.

Acc. to IEC/EN 60 688

Miscellaneous

Additional Error :

Temperature influence

$\pm 0.2\% / 10^\circ\text{C}$

Influence of Variations:

As per IEC/EN 60 688 standard.

Output characteristics:

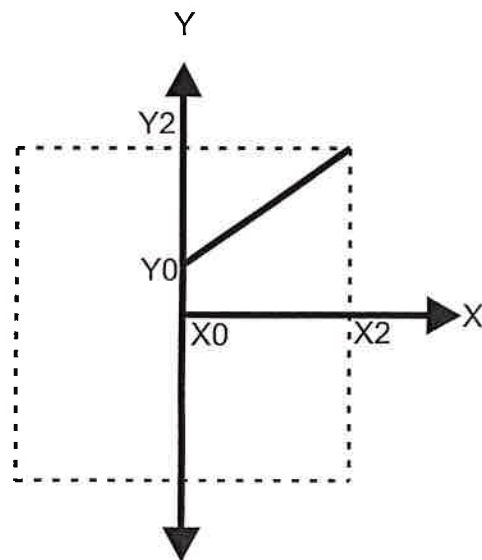
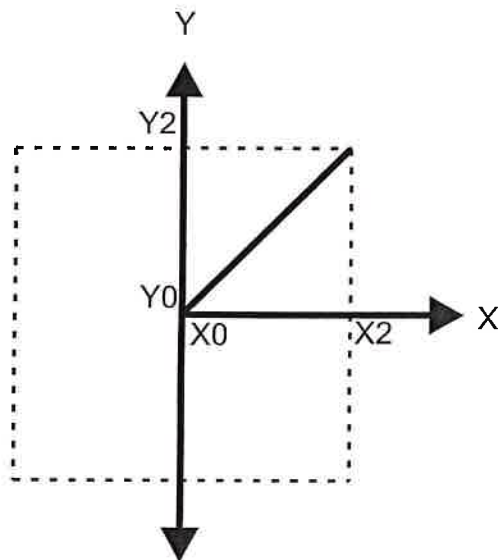

X0 = Start value of input

Y0 = Start value of output

X2 = End value of input

Y2 = End value of output

U_N = Nominal input voltage

I_N = Nominal input current

Safety:

Protection Class	II (Protection Isolated, EN 61 010)
Protection	IP 40, housing according to EN 60 529 IP 20 ,terminal according to EN 60 529
Pollution degree	2
Installation Category	III
Insulation Voltage	50Hz,1min. (EN 61 010-1) 5500V, Input versus outer surface 3700V, Input versus all other circuits 3700V, Auxiliary supply versus input and output circuits.

Installation Data:

Mechanical Housing	Lexan 940 (polycarbonate) Flammability Class V-0 acc. To UL 94, self extinguishing, non dripping, free of halogen
Mounting position	Rail mounting / wall mounting
Weight	Approx. 0.12kg

Connection Terminal:

Connection Element	Conventional Screw type terminal with indirect wire pressure
Permissible cross section of the connection lead	$\leq 4.0 \text{ mm}^2$ single wire or $2 \times 2.5 \text{ mm}^2$ fine wire

Environmental:

Nominal range of use	0 °C... <u>23 °C</u> ... 45 °C (usage Group II)
Storage temperature	-40 °C to 70 °C
Relative humidity of annual mean	$\leq 75\%$
Altitude	up to 2000 m

Ambient tests:

IEC 60 068-2-6	Vibration
Acceleration	$\pm 2 \text{ g}$
Frequency range	10....150...10Hz,
Rate of frequency sweep	1 octave/minute
Number of cycles	10, in each of the three axes
IEC 60 068-2-27	Shock

Acceleration	3 x 50g
	3 shocks in each direction
EN 60 068-2-1/-2/-3	Cold, Dry, Damp heat
IEC 61000-4-2/-3/-4/-5/-6	
EN 55 011	Electromagnetic compatibility.

7. Mounting

The Transducer can be mounted either on a top-hat rail or directly onto a wall or mounting plate.



Make sure that the ambient temperature stays within the permissible limits :
0° C and 45° C

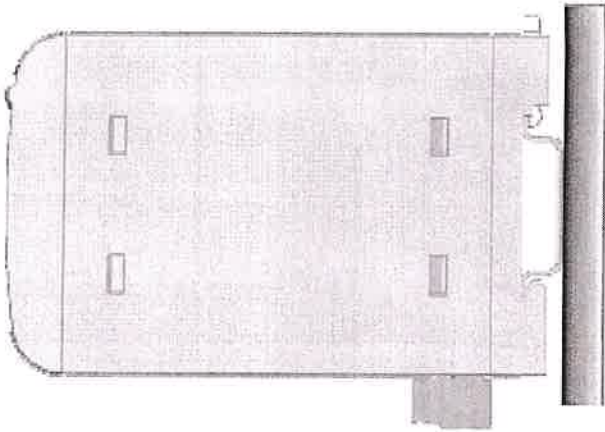

Fig. 3 Top-hat rail Mounting



Fig. 4 Wall Mounting

As the front of the enclosure conforms to IP 40. The terminals of the product should be protected from liquids. Transducer should be mounted in a reasonably stable ambient temperature and where the operating

temperature is within the range 0 to 45°C . Vibration should be kept to a minimum and the product should not be mounted where it will be subjected to excessive direct sunlight.

Caution

1. In the interest of safety and functionality this product must be installed by a qualified engineer, abiding by any local regulations.
2. Voltages dangerous to human life are present at some of the terminal connections of this unit. Ensure that all supplies are de-energised before attempting any connection or disconnection.
3. These products do not have internal fuses therefore external fuses must be used to ensure safety under fault conditions.

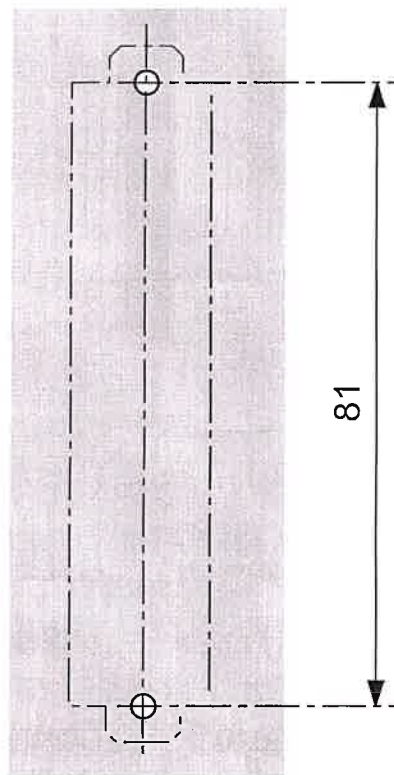

Fig. 5. Drilling plan

Drill 2 holes in the wall or panel as shown in the drilling plan (Fig. 5). Now secure the wall mounting holder to the wall or panel using two 4 mm diameter screws.

8. Electrical connections

Input connections are made directly to screw-type terminals with indirect wire pressure. Choice of cable should meet local regulations. Terminal for Current inputs will accept up to 4.0 mm² single wire or 2 x 2.5 mm² fine wire.



Make sure that the cables are not live when making the connections !

The 230 V power supply is potentially dangerous !

Connection	Terminal details	
Measuring input	~	3
	~	4
Auxilliary Power supply	~ , +	5
	~ , -	6
Measuring output	+	1
	-	2

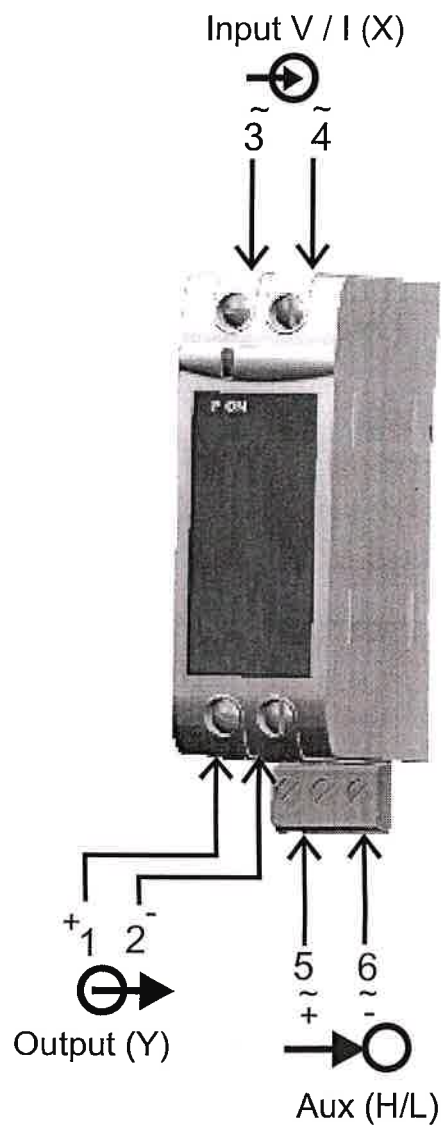
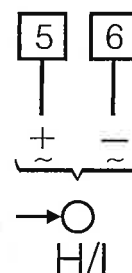
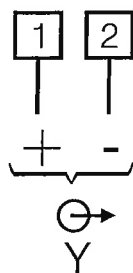

Fig. 6. Front View of Device for electrical Connections



X = Input
 Y = Output
 H/L = Power supply

9. Commissioning

Switch on the measuring inputs and the power supply.
The green LED light remains continuously ON after switching on.

10. Dimensional drawings

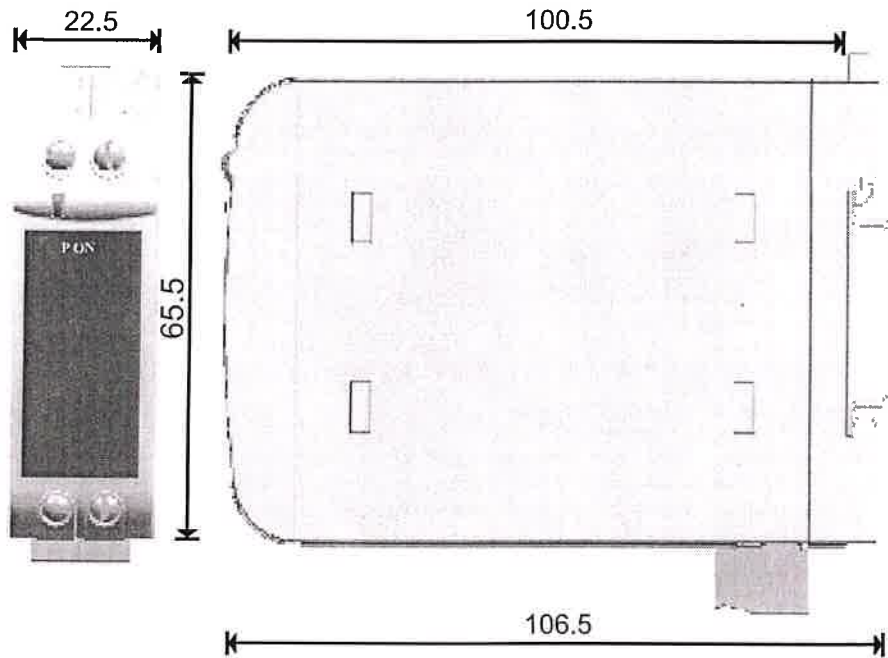

Fig. 7. Transducer Dimensions.

Note : All Dimensions are in mm.

Notes