



Data Sheet

XMER 3PH SERIES



Measure



Control



Record



Analyze

General specification

- # **Applicable standard** : - IEC-61869-1&2 / IEC-60044-1, BS3938, BS7626, IS-2705-1,2&3
- # **Case** : - Unfilled polycarbonate, flame retardant grades classified UL 94V-0.
- # **Insulation class** :- E(120°C max)
- # **Test voltage** :- 3KV 50 Hz for 1 minute.
- # **Operating frequency** :- 50Hz/60Hz
- # **Rated Primary current** :- 40A to 800A
- # **Rated secondary current** :- 5A standard
- # **Continuous current** :-1.2X Rated current
- # **Rated system voltage** :- 0.72/3KV
- # **Ambient temperature range**:- -25°C to +40°C
- # **Storage temperature range**:- -50 to +80°C

Features

- # Compact size.
- # Wide range of system current Ratings.
- # Hinged terminal cover.
- # Various mounting options like DIN rail mounting, Wall mounting.
- # Terminal with self lifting screw with dual connection facility giving access from both sides of transformers.



Measure



Control



Record



Analyze

Data Sheet

XMER 3PH SERIES

RISH XMER 3PH 75-15(60)

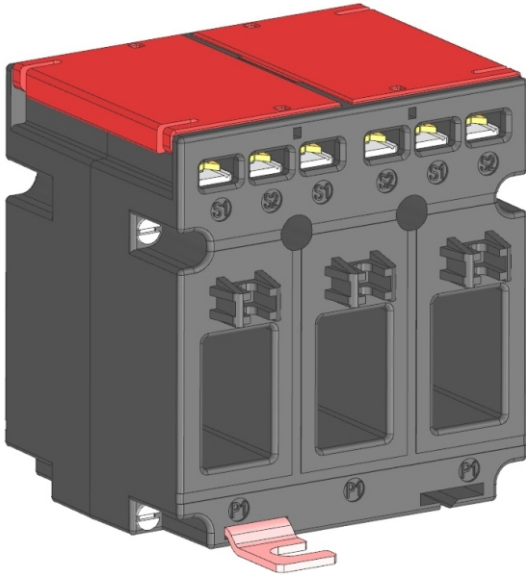

CT Ratio	Class 0.5	Class 1	Class 3
100/5A	-	1VA	2.5VA
125/5A	-	1.5VA	2.5VA
150/5A	1.5VA	1.5VA	2.5VA
160/5A	1.5VA	1.5VA	2.5VA

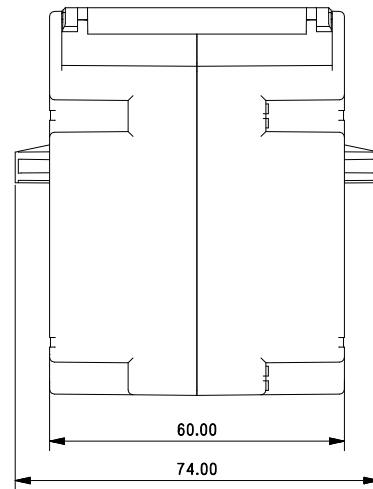
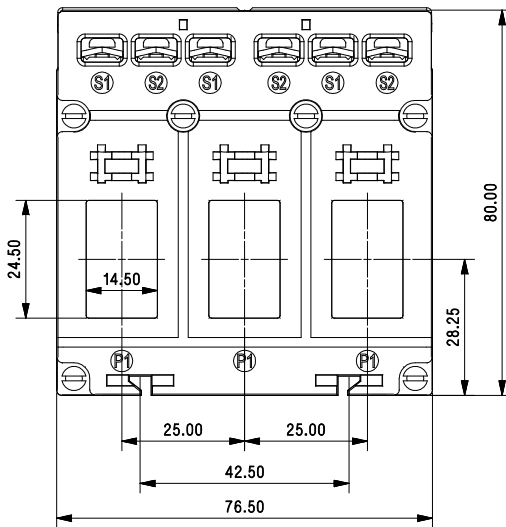

ALL DIMENSIONS ARE IN MM



Measure



Control



Record



Analyze

RISH XMER 3PH 105-21(40)

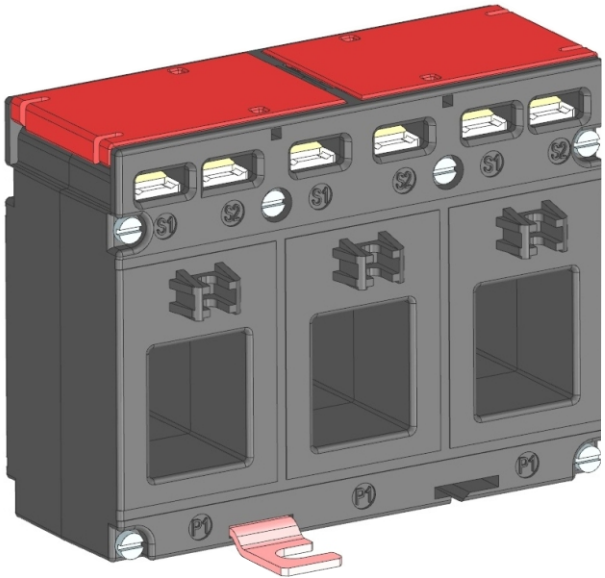

CT Ratio	Class 0.5	Class 1	Class 3
100/5A	-	1 VA	2VA
125/5A	-	1.5VA	2.5VA
150/5A	-	1.5VA	2.5VA
160/5A	1.5VA	1.5VA	2.5VA
200/5A	1.5VA	1.5VA	2.5VA
250/5A	1.5VA	1.5VA	2.5VA

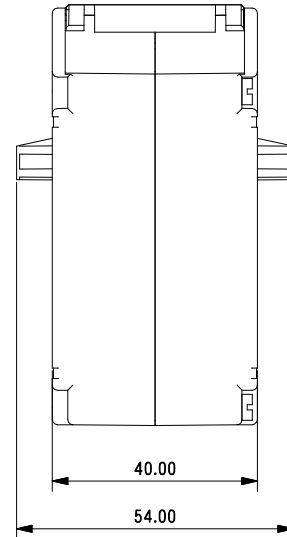
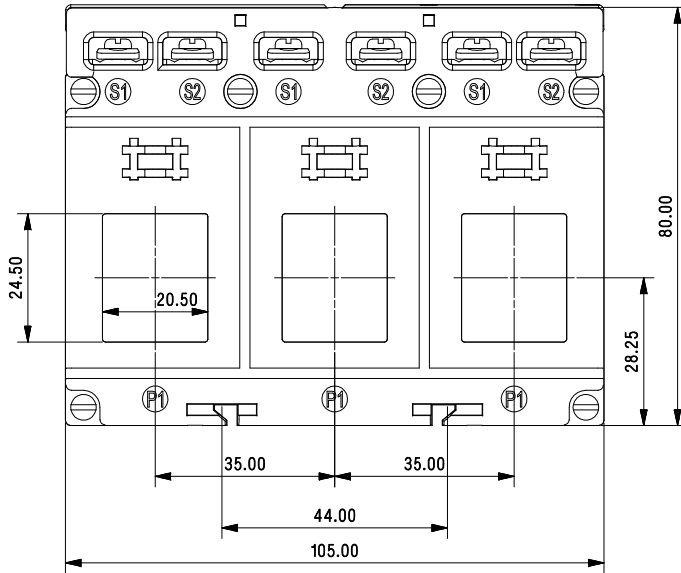

ALL DIMENSIONS ARE IN MM



Measure



Control



Record



Analyze

RISH XMER 3PH 140-31(40)

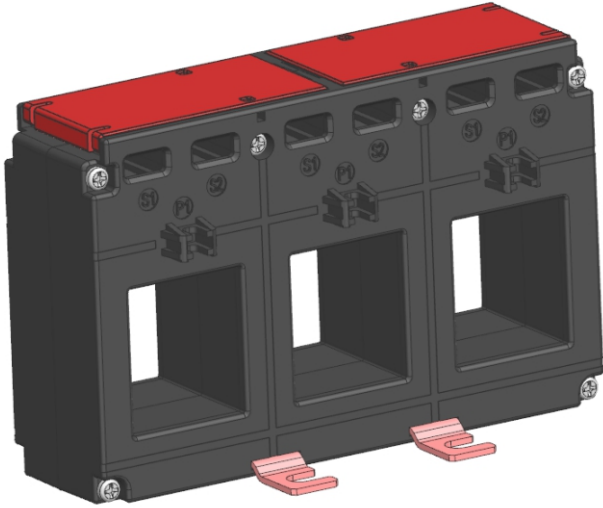

CT Ratio	Class 0.5	Class 1	Class 3
250/5A	1.5VA	1.5VA	2.5VA
300/5A	2.5VA	2.5VA	3.75VA
400/5A	2.5VA	2.5VA	3.75VA
500/5A	2.5VA	2.5VA	3.75VA
600/5A	2.5VA	2.5VA	3.75VA
630/5A	2.5VA	2.5VA	3.75VA

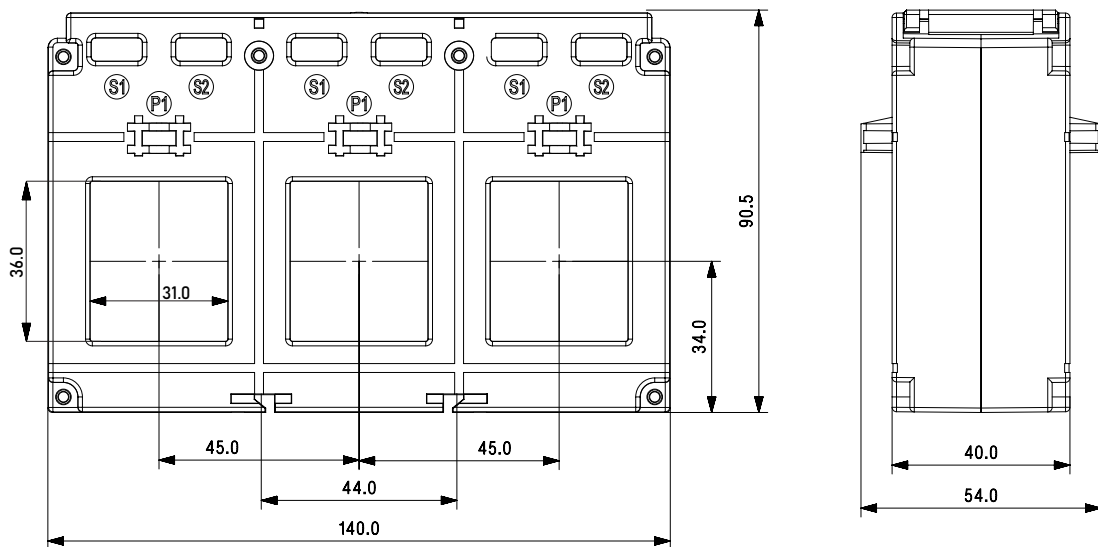

ALL DIMENSIONS ARE IN MM



Measure



Control



Record



Analyze

Data Sheet

XMER 3PH SERIES

RISH XMER 3PH 185-27(45)

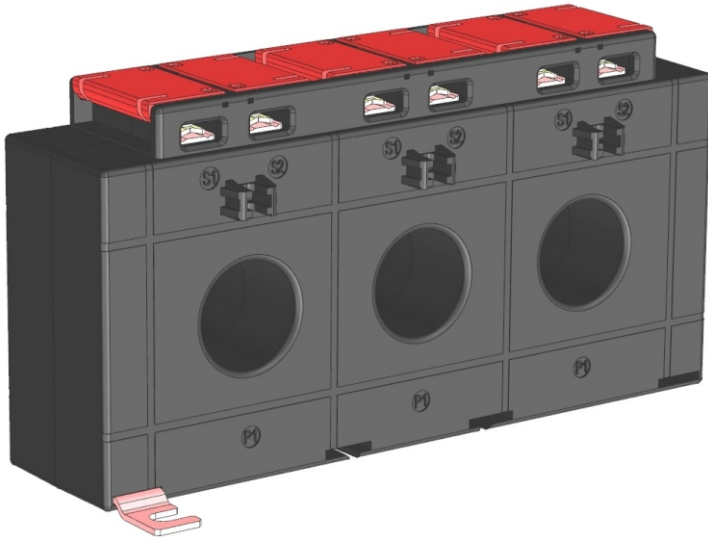

CT Ratio	Class 1	Class 3
40/5A	-	1.25VA
60/5A	-	1.5VA
80/5A	-	1.5VA
100/5A	1.5VA	1.5VA
150/5A	1.5VA	1.5VA
200/5A	2.5VA	2.5VA
250/5A	2.5VA	2.5VA
300/5A	5VA	5VA
400/5A	5VA	5VA
500/5A	5VA	5VA

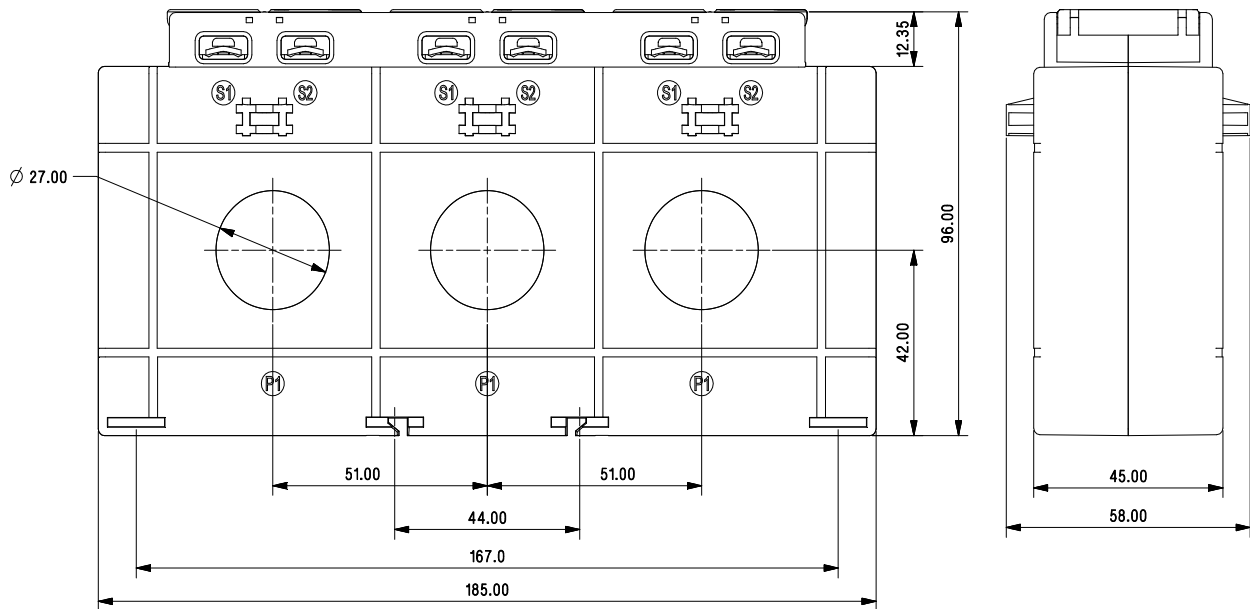

ALL DIMENSIONS ARE IN MM



Measure



Control



Record



Analyze

Data Sheet

XMER 3PH SERIES

RISH XMER 3PH 185-37(45)

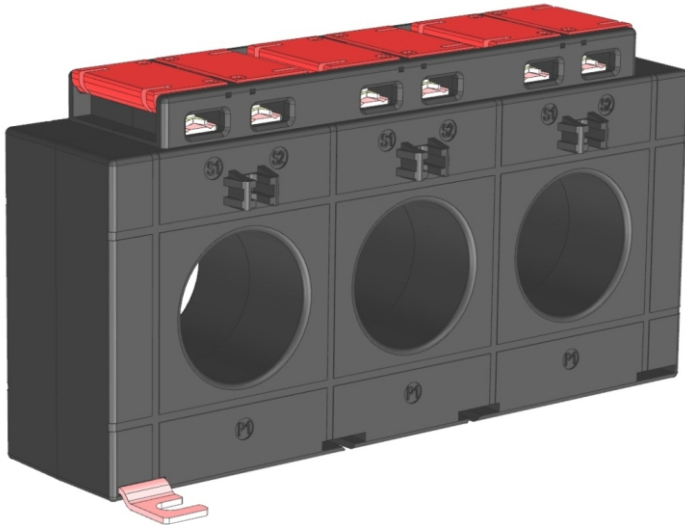

CT Ratio	Class 1	Class 3
300/5A	2.5VA	2.5VA
400/5A	5VA	5VA
500/5A	5VA	5VA
600/5A	5VA	5VA
800/5A	5VA	5VA

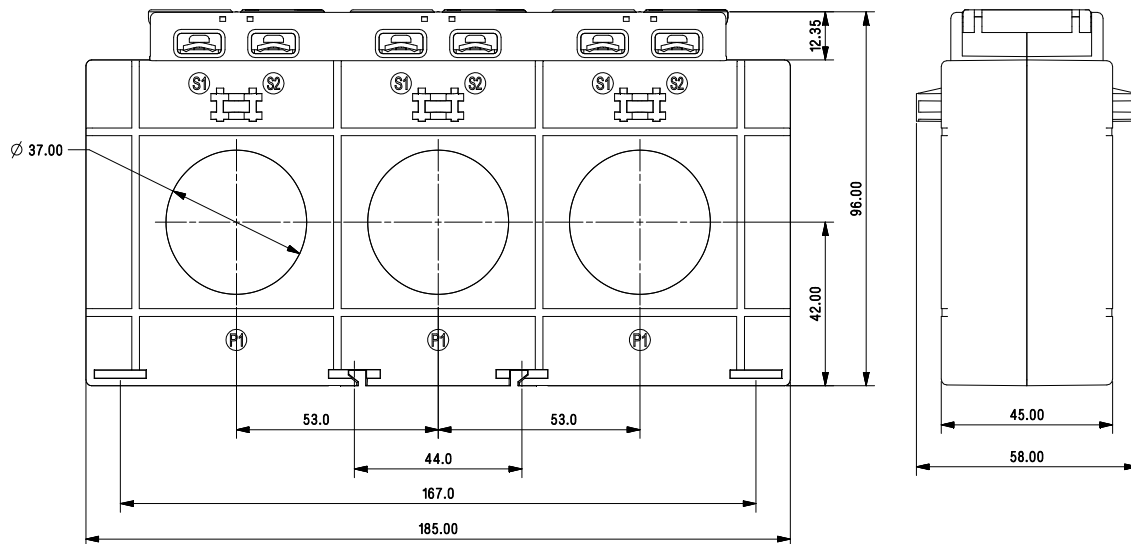

ALL DIMENSIONS ARE IN MM



Measure



Control



Record



Analyze



RISHABH



Measure



Control



Record



Analyze

RISHABH INSTRUMENTS LIMITED

Domestic (India): +91 253 2202099 | marketing@rishabh.co.in
International: +91 253 2202004/06/08/99 | global@rishabh.co.in
www.rishabh.co.in