



Datasheet

RISH CON-I11



Measure



Control



Record



Analyze

Application:

The transducer **RISH CON-I11** (Fig.1) converts a sinusoidal AC Current into a load independent DC current or a load independent DC voltage proportional to the measured value.

Salient Features:

- ≈Arithmetical mean value measurement Calibration to RMS with sine waveform (Average Value)
- ≈Accuracy class 0.5 as per international standard
- ≈IEC/EN60 688
- ≈**Single Isolated DC currents or DC voltage outputs.**
- ≈Response time < 200 ms
- ≈Fast and easy installation on din rail or onto a wall or in panel using optional screw hole bracket.



Fig. 1 RISH CON-I11

Product Features:

Measuring Input:

AC Current input signal , sine wave.

Analog Output (Single):

Isolated analog output which can be Current or Voltage.

Accuracy:

Output signal accuracy **class 0.5** as per International Standard **IEC/EN 60 688**.

LED Indication:

LED indication for power ON.

Symbols & Their Meaning

Symbols	Meaning
X	Measuring input / Input variable
X0	Start value of input voltage / current
X1	Elbow of input voltage
X2	Final value of input voltage / current
Y	Measuring output / Output variable
Y0	Start value of output variable
Y1	Elbow of output variable
Y2	Final value of output variable
H	Power supply
R_{ext} Max	Max. output burden



Measure



Control



Record

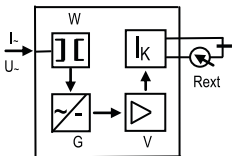
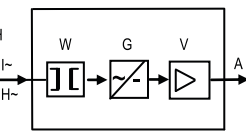
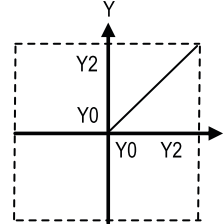

Analyze

Layout and Mode of Operation	Block Diagram	Standard Transformation Characteristics
<p>I11 The Transducer comprises a transformer W, a rectifier unit G and the amplifier V. The measured variable I/U AC is isolated from the electronics by the transformer W, and is rectified and smoothed in the rectifier unit G. The o/p amplifier V amplifies the resultant signal and converts it into the load-independent DC o/p signal A. The version with live-zero o/p has a 4mA constant current source to provide the zero setting. In the case of 2-wire connection the o/p increases from the zero setting of 4mA with an increase in measured value. The constant current source needs a supply voltage H between 12 and 30 V DC, which may be supplied typically from the main installation, the receiving equipments or a separate power pack.</p>	<div style="display: flex; justify-content: space-around;"> <div style="text-align: center;">  <p>Fig. 2 Block diagram for transducer with live-zero output & 2-wire connection</p> </div> <div style="text-align: center;">  <p>Fig. 3 Block diagram for transducer with unipolar Output.</p> </div> </div>	<div style="text-align: center;">  <p>Fig. 4 Linear curve, characteristics (X0 = 0; Y0 = 0.2 Y2)</p> </div>

Technical Specifications:

Current Transducer (RishCON - I11)

Final value of Nominal Input Current IN (X2) AC RMS	1A, 5A.
Nominal Frequency FN	50 or 60Hz.
Nominal Input Current Burden	Full O/p value [mA] [VA]
	1 <0.8VA at IN
	5 <1.8VA at IN
	10 <2.2VA at IN
	20 <2.8VA at IN
Overload Capacity	1.5*IN Continuously, 2*IN for 10 second, repeated 10 times at 10 second intervals, 10*IN for 3 second, repeated 5 times at 5 minute intervals, 40*IN for 1 second, 1 time.

Measuring output Y

Output type	Load independant DC current IA or DC voltage output VA (Not superimposed)
Load independent DC current Output range	0...1/0...5/0...10/0...20 mA
Output burden with DC current output signal	4...20 mA
DC voltage output range	Rext max. [k ohm] = 15 VA/IAN [mA]
Output burden with DC current output signal	IAN = full output value
Current limit under overload	Output VA not superimposed : std range of VA: 0...10V
Voltage limit under Rext = ∞	Rext ≥ 200kΩ/V
Residual Ripple in output signal	≤1.5 * IAN for current output
Response time	Approx. 30 mA for voltage
Output standard ranges	<24 V
	Current Ripple ≤1%p.p.
	<200ms
	Current : 0...1/0...5/0...10/0...20 mA
	Voltage : 0-10V

Auxiliary supply

Self powered



Measure



Control



Record



Analyze

Accuracy (Acc. to IEC/EN 60688)

Reference value
Accuracy Class

Input end value X2
0.5

Reference conditions for Accuracy

Ambient temperature
Pre-conditioning
Input variable

23°C, ± 5k
≤ 5 min.
0 to 100% for current measurement
20 to 100% for voltage measurement
Sinusoidal.
1.1107
50...60Hz ± 2%
< 0.5%
Current output 0 - R_{ext} Max.
Voltage output R_{ext} Max to ∞
± 1% for 24Vdc with 4...20mA output.

Input waveform shape
shape factor
Input signal frequency
Distortion factor
Output load

Power Supply

Influence Effects (maxima) :

Linearity error
Frequency
Dependences on external resistance
Δ R_{ext} Max

< ± 0.3%
± 0.3% (Fn ± 0.2%)
± 0.1%

Additional Errors

Temperature influence
Curve shape of Input
Frequency of input variable
Influence of Variations

± 0.2% /10°C.
Sine waveform only
45...200Hz ± 0.5%
As per IEC/EN 60 688 standard.

Power Supply

DC power supply

12-30V (only for 2-wire connection with output 4...20mA)

Output Characteristics

2 wire output with 4...20mA, 12...30V DC AUX:
With 2 wire connecton

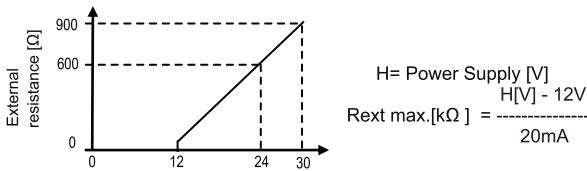

Fig. 5

Standard ranges of IA = 4...20mA,
External Resistance R_{ext} -dependent
on power supply H(12...30V DC)

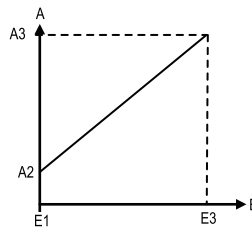

Fig. 6

Characteristics A
"Standard and live zero."

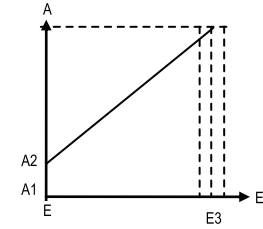

Fig. 7

Characteristics A "Standard"
Variable Sensitivity and live zero.

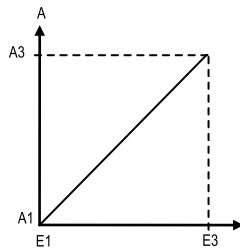

Fig. 8

Characteristics A
"Standard"

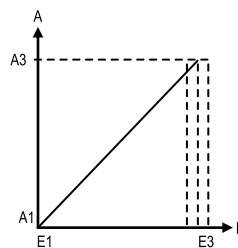

Fig. 9

Characteristics A "Standard"
Variable Sensitivity".
E3 ±5% or ±10%



Measure



Control



Record



Analyze

Safety:

Protection Class	II (Protection Isolated, EN 61010)
Protection	IP 40, housing according to EN 60529 IP 20 ,terminal according to EN 60529
Pollution degree	2
Insulation Voltage	7750VDC, Input versus outer surface 7750VDC, Output versus outer surface 5500VDC, Input versus output
Impulse withstand Voltage Acc to IEC 255-4 CI,III	5kV 1.2/50 sec, 0.5Ws common mode and differential mode between any terminals

Installation Data:

Mechanical Housing	Lexan 940 (polycarbonate) Flammability Class V-0 acc. To UL 94, self extinguishing, non dripping, free of halogen Rail mounting / wall mounting
Mounting position	
Weight	Approx. 0.35kg
Product Performance	IEC EN 60 688

Connection Terminal

Connection Element	Conventional Screw type terminal with indirect wire pressure
Permissible cross section of the connection lead	≤ 4.0 mm ² single wire or 2 x 2.5 mm ² fine wire

Environmental

Operating temperature	-25 °C...23 °C... 55 °C
Storage temperature	-40 °C to 70 °C
Relative humidity of annual mean	≤ 75% Standard Climatic Rating ≤ 90% Enhanced Climatic Rating
Altitude	2000m max

Ambient tests:

EN 60068-2-6	Vibration
Acceleration	± 2 g
Frequency range	10....150...10Hz, rate of frequency sweep: 1 octave/minute
Number of cycles	10, in each of the three axes
EN 60068-2-7	Shock
Acceleration	3 x 50g 3 shocks in each direction



Measure



Control



Record



Analyze

Electrical Connections:

Connection	Terminal details	
Measuring input	~	5
	~	6
Measuring output	+	1
	-	2
Not Connected	NC	3,4,7,8

LED Indication:

ON LED	Power ON	Red LED continuous ON
--------	----------	-----------------------

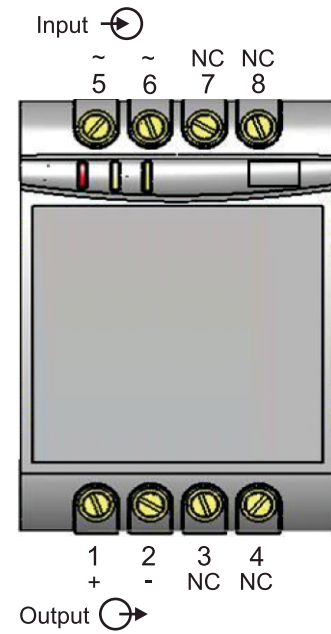

Fig 10. RishCON- I11 Connection diagram

Dimensions:

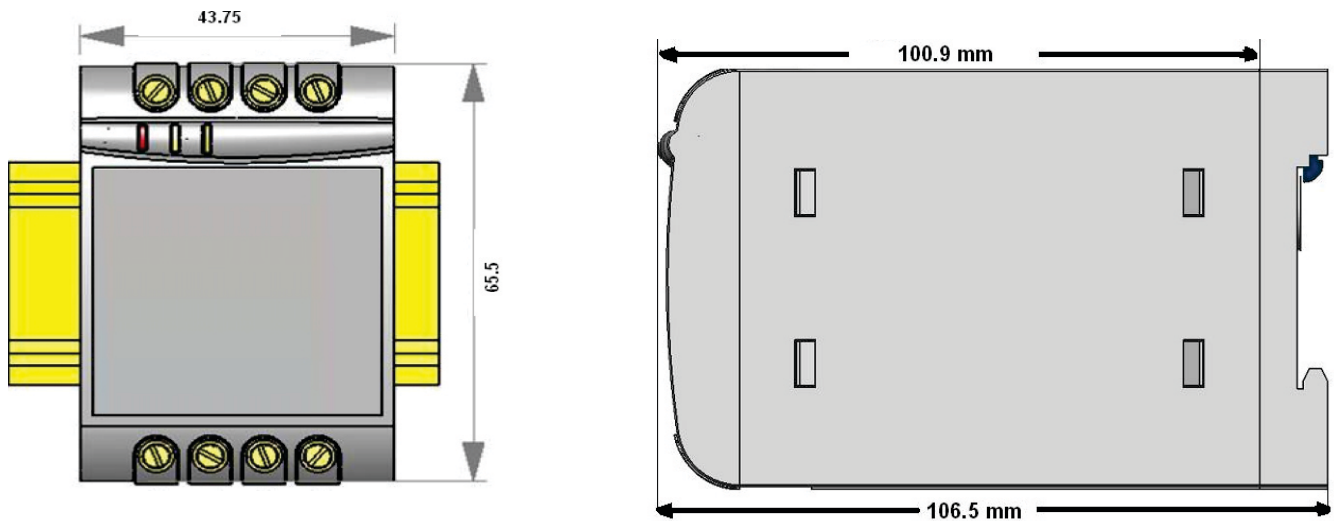

Fig 11. RishCON- I11 Dimensions

Note: All dimensions are in mm.



Measure



Control



Record



Analyze

Ordering Information: Standard Version :

Single Output : RISH CON - I11

Product Code	CA11-	X	XX	XX	00000000
Model	AC CURRENT TRANSDUCER Class 0.5	A			
Input Current range	Fixed Input : 0...1A		11		
	Fixed Input : 0...5A		51		
Output	0 ... 10mA			01	
	0 ... 5mA			02	
	0 ... 20mA			03	
	4 ... 20mA			04	
	0...10V			05	

Ordering Example:

CA11-A693200000000 - RishCON- I11, Input: 5A,output: 0...20mA.



Measure



Control



Record



Analyze



RISHABH



Measure



Control



Record



Analyze

RISHABH INSTRUMENTS LIMITED

Trishala Unit, C-6, NICE Area, MIDC, Satpur, Nashik - 422007, India.

Tel: +91 253 2202028 | Fax: +91 253 2351064 | E-mail: marketing@rishabh.co.in | www.rishabh.co.in