

SQ 96
SQ 144

Data Sheet

Electronic
Synchroscope

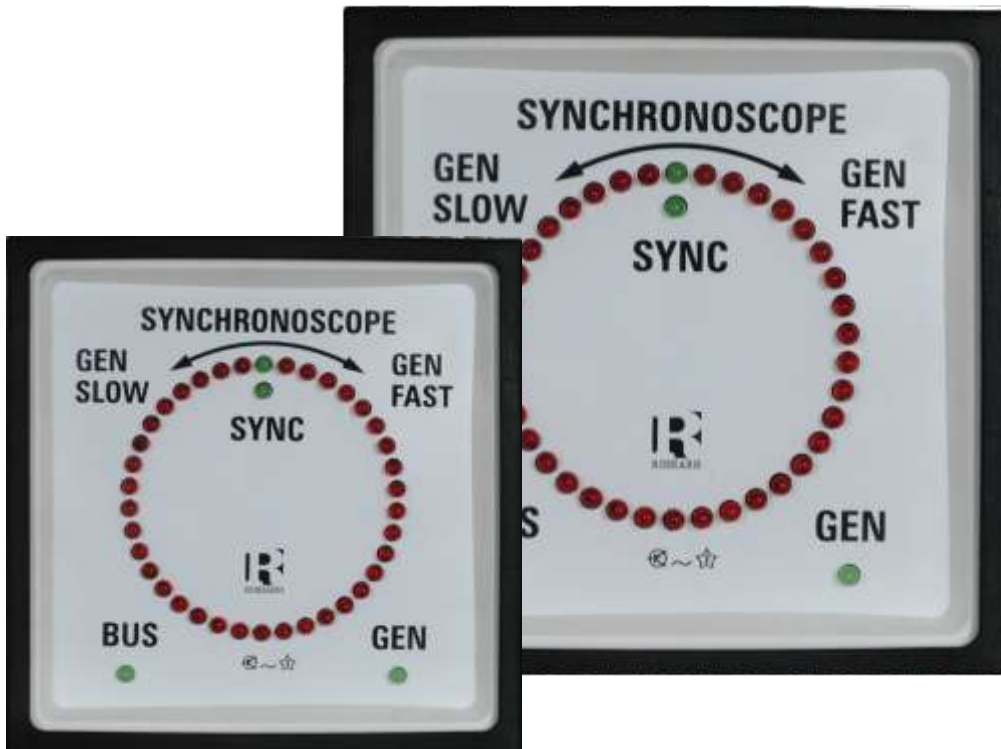

Application

The Electronic Synchroscope is designed to provide an illuminated indication of actual phase difference between the BUS Voltage(reference voltage) & the GENERATOR Voltage(incoming voltage)

It denotes the actual frequency difference corresponding to the inverse of time taken for one rotation of the illuminated vector spot. When two alternators are paralleled, it is necessary that,

- 1) Frequency must be equal.
- 2) Phase must be same.

Synchroscope is, hence used to indicate the Phase & Frequency difference between two AC alternators, which are to be paralleled.

Description

The rotation of the vector spot is with reference to the bus voltage.

If the vector spot LED turns clockwise, it indicates the GENERATOR frequency is greater than the BUS frequency. It means the speed of the generator must be reduced by the operator.

If the spot LED turns anticlockwise, the GENERATOR frequency is less than BUS frequency. In this case speed of the generator must be increased.

If 'T' is the time taken for one rotation, the frequency difference can be calculated as $1/T = \Delta f$

Example: Let the bus frequency be 50 Hz. The vector spot takes 10 Sec. for one rotation, clockwise.

$$1/10 = 0.1 \text{ Hz.}$$

The frequency difference = 0.1 Hz. Hence we can infer that GENERATOR frequency is 50.1 Hz.

If the Frequency & Phase of BUS signal matches with those of GENERATOR signal, the two green LEDs at 12 o'clock position glow.

If the Frequency matches & Phase does not, then one red LED corresponding to the phase difference will glow.

Favorable condition for "Switching in" the Generator

1. Ensure that the frequency difference between two inputs is within the requirements of user as follows:

Measure time taken for 1 complete rotation of the vector spot in SECOND(T).

The frequency difference will be $\Delta f = 1/T(\text{Hz})$

2. Provided the frequency difference is within acceptable limits, wait till the SYNC mark LED s (two green LED s at 12 o'clock position) glow. At this instant, it is safe to CONNECT the GENERATOR to BUS

Functional Principle

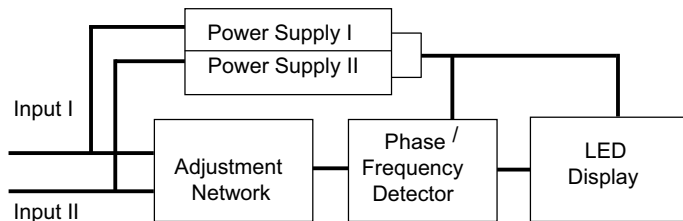

The Bus & Gen inputs are fed to the Frequency & Phase detection network. The output duty cycle of the network corresponds to the frequency difference between Bus & Generator Voltage. The detector network also determines the actual phase difference.

Mechanical Data

Case details	Moulded square case suitable for mounting in Control / Switchgear panels, machinery consoles.
Case material	Glass filled polycarbonate, flame retardant and drip proof as per UL 94 V-O.
Front facia	Glass
Colour of bezel	Black
Position of use	Vertical
Panel fixing	Swivel screws.
Mounting	Stackable in a single cutout
Panel thickness	≤ 40 mm
Terminals	Hexagon studs, M4 screws and wire clamps E3 (DIN 46282)

Electrical Data

Measured quantity	Frequency & Phase difference
Power consumption	6 VA Max
Enclosures code (IEC 529)	IP 52 case
Insulation class	IP 00 for terminals
Insulation voltage	group A according to VDE 0110
Proof voltage	660 V
Frequency range	2kV
Pull in / drop out Freq.	35-70 Hz
Installation category (IEC1010)	+ / - 9 Hz
insulation resistance	300 V CAT III
Reference conditions	> 50 Mohm at 500 V d.c.
Ambient temperature	23°C + 3°C
Input Voltage	Rated voltage ± 2%
Rated frequency	50 Hz ± 0.1 %

Environmental Conditions

Climatic suitability	Climate category II as per IS : 1248 (climatic class 3 according to VDE / VDI 3540)
Operating temperature	- 10...+ 55 ° C
Storage temperature	-20...+ 65 ° C
Relative humidity	≤ 75 % annual average non - condensing
Shock resistance	15g, 11ms
Vibration resistance	10-150-10 Hz / 0.15 mm / 5 Cycles / 10 octave per minute.

Applicable Standards

Nominal case and cutout dimensions for indicating measuring instruments	IS 2419 DIN 43700
Connections and Terminal markings for panel meters	IS 1248 DIN 43807
Terminal bolts / leads.	DIN 46200/46282
Clamp straps for connections	DIN 46282
Safety requirements and protective-measures for Electrical indicating-instruments and their accessories.	IS 9249 - 1979 DIN 40050 / 8-70, VDE 0110/ 11-72 VDE 0410/ 10-76 IEC 529, IEC 1010
Performance specification for direct acting indicating analogue electrical	IS 1248-1983 IEC 51/DIN EN 60051
measuring instrument and their accessories	IS 1248 - 1983
Environmental conditions	IS: 9000 VDE / VDI 3540 DIN 43718
Front frames for indicating measuring instruments principal dimensions	UL 94 V-0
UL Combustibility Class	DIN 43701
Technical conditions of delivery for electrical instruments	
Mechanical Strength (Free fall test, Vibration test)	IS 1248/IEC 51 IEC 1010, IS 9000-1979 VDE 0411, part 1 Sec 43/44

Options

Case	
Front facia	Antiglare glass
Colour of bezel	Red, Yellow, Blue, White.
Colour of LED s	Orange, Yellow
Dial	
Special markings	Numbering / Lettering.

Connections

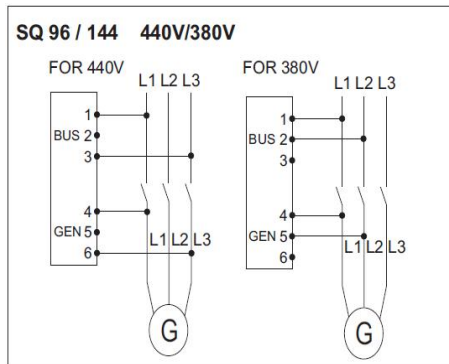

Type	Terminal	
	1-3	1-2
BUS	1-3	1-2
GEN	4-6	4-5
SQ - 96	440V	380V
SQ - 144	240V	220V
	480V	415V
	110V	100V
	127V	120V

Ordering Information

Type	Electronic Sychroscope	
SQ	Electronic Sychroscope	
Front Dimension	96,144	
Rated voltages	Refer to selection table inside	
Front facia	Normal glass ¹ Antiglare glass ³	
Colour of Bezel	Black ¹ Red, Blue, Yellow, White ³	
Position of use	Vertical (0-360°) ¹	
Dial	Additional lettering on request ³ Additional numbering on request ³	
Logo	RISHABH ¹ , for Indian Sales. C.G ¹ , for export through Crompton Greaves I.D. Others ³	

Dimensions

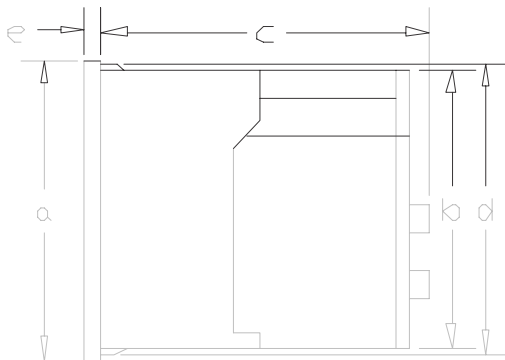

Dimensions (in mm)		SQ 96	SQ 144
Bezel	a	p96	p144
Case	b	p90	p136
Depth	c	106	106
	d	p 91.5	p137.8
	e	5.5	8.5
Cutout Size		p 92 ^{+0.8}	p 138 ⁺¹
Weight (approx.)		0.60Kg	0.70Kg

Safety Precautions

- Instruments with damaged bezels or window glasses must be disconnected from mains.
- Adequate safety clearance must be maintained to control panel fasteners and to sheet metal housing, if non-insulated connector wires are used.
- Bezels and window glasses should be replaced under Voltage - free conditions.

¹Standard

²Please clearly add the desired specifications while ordering

Ordering example

SQ 96, rated voltage AC 230 V.

Specifications are subject to change without notice(10/98)



RISHABH
INSTRUMENTS
Measure, Control & Record with a Difference

RISHABH INSTRUMENTS PVT.LTD.
F-31, MIDC, Satpur, Nashik-422 007, India.
Tel.: +91 253 2202160, 2202202 Fax : +91 253 2351064
E-mail : India :- marketing@rishabh.co.in
International :- exp.marketing@rishabh.co.in
www.rishabh.co.in