



Data Sheet

RISH MD1340 - RJ12

Multifunction Meter - DIN Rail mounted



Measure



Control



Record



Analyze



Optimize

RISH MD1340 measures important electrical parameters in 3 phase 4 wire, 3 phase 3 wire and 1 phase 2 wire Network. It displays many parameters at a glance. It measures electrical parameters like Active / Reactive / Apparent energy and all basic parameter. The instrument has optional digital output available as potential free relay or SO interface and configurable as pulse or alarm. This instrument also has optional digital inputs for monitoring the external contact status, pulse counting and/or energy accumulation according to tariff.

Applications

- Internal Energy billing/monitoring/auditing
- Sub-metering
- Electrical load monitoring
- Genset, Test Benches and Laboratories

Product Features

Plug and Play Current Transformer

RJ-12 connector is available for external CT connection, which enables easy, fast and error free installation. 2 meter long cable is provided with CT

True RMS measurement

True RMS measurement with Sampling rate of 128 samples per cycle

Relay Output (optional)

Potential free, very fast acting relay contact configurable for following:

- **Pulse** output which can be used to drive an external counter for energy measurement
- **Limit** (alarm) switch. Limit output also configurable for three logical combination of parameters
- **Timer** output which can be used to operate relay in cyclic manner
- **Pre-Paid Cost** based energy tripping
- Switch for **unhealthy three phase load**
- **Remote Relay Control** using MODBUS

Pre-Paid Cost Based Energy Tripping

- This feature provides the luxury of tripping the load whose energy has crossed the required threshold of the configured tariff amount
- The user just needs to set the energy, top-up amount and the rate per unit (kilo) of energy

Health Monitoring of Three Phase Load

- This feature is applicable only for Three phase load (such as a Three phase motor) which can be monitored for phase failure, phase reversal, voltage & current unbalance, under frequency, under voltage, over voltage and over current
- Further, set a relay on this mode and use it for indication / guard against such faults

Pulse Output (SO Output)

- Opto-isolated pulse output
- Configurable for Active, Reactive and Apparent Energy Parameters
- The pulse rate and pulse duration is also onsite configurable

High Max System Power Limit

- Upto 3750 MVA Nominal System Power is measurable
- Upto 9000 MVA Max System Power is measurable

Compliance to Performance Standards

Compliance to performance standard IEC 61557-12, IEC 62053-22 and 62053-23

Energy as per IEC 62053

- Active Energy accuracy 0.5s as per 62053-22 and Reactive Energy Class 2 as per 62053-23
- Independent Import and Export Energy counter. Active energy (kWh), Reactive energy (kVArh), Apparent energy (kVAh) measurement of system as well as phase-wise

Digital Inputs

2 Digital Inputs (Optional) can be configured as:

- Status to indicate if the input is present or not
- Pulse Counter for counting pulses from external sources
- Tariff Input to store separate energy counters on the basis of digital inputs present

Dual Tariff

- 2 Tariff based on digital input available
- 6 Energy Parameters configurable for tariff based energy

THD and Individual Harmonics Measurement

The instrument measures per phase THD and individual harmonic up to 31st harmonics for voltage & current

Direct Remote Access (Optional)

Remote configuration of the Instrument and access of measured parameter via MODBUS RS485

Min-Max Values and Old Values

- Min-Max Voltage, Current, Active/Reactive/Apparent power, Power factor, Phase angle, Frequency
- Old value storage after Reset

EMC Compatibility

Compliance to International standard IEC 61326



Measure



Control



Record



Analyze



Optimize

Product Features

User Assignable Screens

- Instrument measures more than 85 parameters and these parameters are displayed through different screens.
- User can select minimum 1no. and maximum 10 nos. of screens out of all the screens as per application requirement.
- For example: If 5 screens are selected, then display will scroll among that 5 selected screens.

Compliance to International Safety Standards

Compliance to International Safety standard IEC 61010-1- 2010.

Dimensions Details

Front View

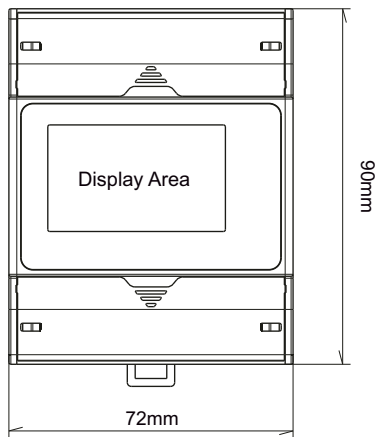

Side View

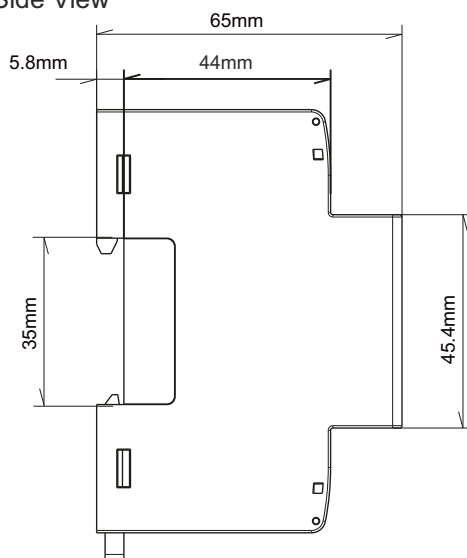

Technical Specifications

Input Voltage:

Nominal input voltage (Vn)	100VLL to 600 VLL AC RMS
Programmable on site.	57.5VLN to 346.42 VLN AC RMS
System PT primary values	100VLL to 1200kVLL programmable on site.
Measuring Range	20%....120% of nominal value
Overload Withstand	2 x rated value for 1 second, repeated 10 times at 10 second intervals
Overload Indication	"-OL-" >121% of Nominal value
Nominal input voltage burden	< 0.3VA approx. per phase (at nominal 240V)

Input Current

Nominal input current (In)	100mA
System CT primary values	From 1A to 9999A
Measuring Range	1%....120% of nominal value
Overload Indication	"-OL-" >205% of Nominal value
Nominal input current burden	< 0.05VA approx. per phase

Auxiliary Supply

Higher Auxiliary supply range	100-550V AC/DC (230V AC/DC nominal)
As per IEC 61557-12	100-320V AC/DC (230V AC/DC nominal)
Aux Supply frequency	45 to 66 Hz range
Auxiliary Supply burden	< 6VA approx. (at nominal value)

Operating Measuring Ranges

Current (Energy Measurement)	1....120% of nominal value
Starting current	As per Standard IEC62053-22(0.5s)
Voltage	20...120% of nominal value
Power Factor	0.5 Lag ... 1... 0.8 Lead
Frequency	40Hz to 70Hz



Measure



Control



Record



Analyze



Optimize

Top View

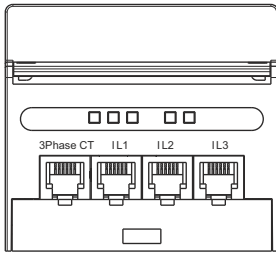

Note: For Single 3 phase CT Connect directly to 3 Phase CT Slot.
For three individual phasewise CTs connect them to IL1,IL2,IL3 slots respectively.

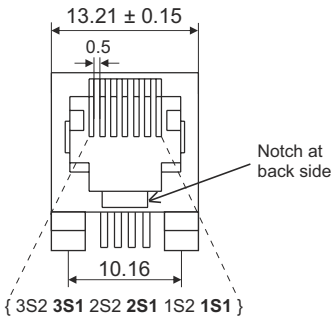

Meter Side RJ 12 Connection

Electrical Connections

Network Types :

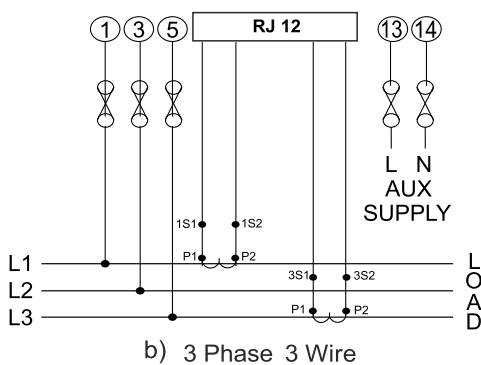
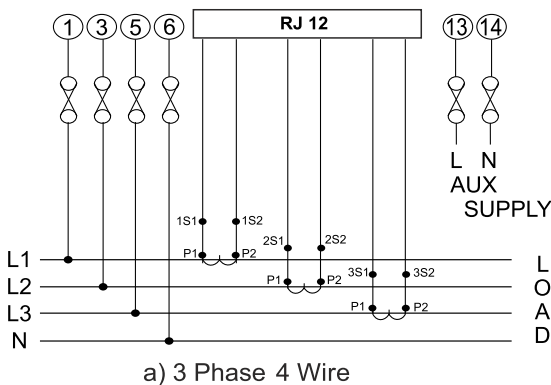

Technical Specifications:

Reference Conditions for Accuracy

Reference temperature	23°C +/- 2°C
Influence of temperature	0.01% / °C for Voltage, 0.025% / °C for Current
Input Waveform	Sinusoidal (distortion factor 0.005)
Input frequency	50/60 Hz ± 2%
Auxiliary supply frequency	50/60 Hz ± 1%
Total Harmonic distortion	THDv ≤ 50% upto 31st at Vn THDi ≤ 60% upto 31st at In
Voltage range	20%.....120% of nominal value
Current range	10%.....120% of nominal value

Display Specification

Display	3 Line 4 Digit LCD with Backlit
Response time to step input	1 sec approx.
LED Indications	Impulse (Integration of Energy)
Display scrolling	Automatic/Manual (Programmable)
Push buttons	4 Buttons

Accuracy

Active Energy	Class 0.5s as per IEC 62053 - 22
Apparent Energy	Class 0.5 as per IEC 61557 - 12
Reactive Energy	Class 1 as per IEC 61557 - 12
Active Power	Class 2 as per IEC 62053 - 23 & IEC 61557 - 12
Re-Active Power	± 0.5% of Nominal value
Apparent Power	± 1.0% of Nominal value
Power Factor/Phase Angle	± 0.5% of Nominal value
Voltage	± 0.5% of nominal value
Current	± 0.5% of nominal value
Frequency	± 0.2% of nominal value
THD (V/I) w.r.t. fundamental	± 5% (upto 31st Harmonics)
Individual Harmonics	± 5% (upto 31st Harmonics)

Applicable Standards

Electromagnetic Compatibility	IEC 61326 - 1
Immunity	IEC 61000-4-2,-3,-4,-5,-6,-8,-11
Emission	CISPR 11
Safety	IEC 61010-1-2010
IP for water & dust	IEC 60529
Pollution degree	2
Installation category	III
Protective Class	2
High voltage test:	
• Input + Aux Vs Surface	4kV RMS, 50Hz for 1min
• Input / Aux Vs Others	3.3kV RMS, 50Hz for 1min
DI / Pulse Out / RS485 Vs Others	3.3kV RMS, 50Hz for 1min
DI Vs DI / Pulse out Vs Pulse out	2.2kV RMS, 50Hz for 1min



Measure



Control



Record



Analyze



Optimize

Electrical Connections

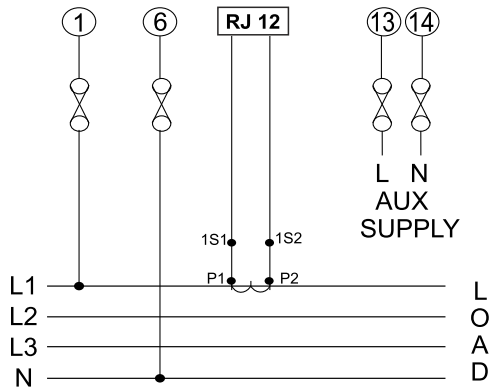

c) Single Phase Load

Wiring Guidelines

Solid with Pin type lugs (sq. mm)	1 to 2.5
Stranded with pin types lugs (sq. mm)	1 to 2.5
Torque value (Nm)	
1. Aux and Voltage terminals	0.5 to 0.6
2. RS485, DI and Relay terminals	0.3 to 0.4
Length available for lug entry in terminal (mm)	9.5

It is recommended that the wires used for connections to the instrument should have lugs soldered at the end. That is, the connections should be made with Lugged wires for secure connections.

Technical Specifications

Environmental

Operating temperature	-20 to +55°C
Storage temperature	-40 to +85°C
Relative humidity	0... 95% (non condensing)
Warm up time	Minimum 3 minute
Shock (As per IEC 60068-2-27)	Half sine wave, Peak acceleration 30gn (300 m/s ²), duration 18ms
Vibration	10... 150...10 Hz, 0.15mm amplitude
Altitude	< 2000 m
Number of Sweep cycles	10 per axis
Enclosure	IP 20 (Terminal side) and IP 54 (Front side)

Installation

Mechanical Housing	Lexan 940(polycarbonate), Flammability, Class V-0 acc. to UL 94, self extinguishing, non dripping, free of halogen
Mounting Position	DIN Rail Mounted
Connection Element	Conventional screw type terminal with indirect wire terminals
Connection Terminal	4 mm ² solid or 2.5 mm ² stranded cable
Weight	300 grams approx

Interfaces

Impulse LED	For Energy testing
2 Digital Input (Optional)	20... 300 VAC / 10... 60 VDC, Optical couplers, Min width 10ms, Min length b/w 2 pulses 18ms
Relay (Optional)	250 VAC, 5 AAC 30 VDC, 5A DC
SO Output (Optional)	Opto-coupler max. 30V, 20mA, at least 5V Pulse width 30ms, Impedance 100 ohm
Modbus (Optional)	RS485, max 1.2Km : 4.8,9.6,19.2,38.4,57.6kbps



Measure



Control



Record



Analyze



Optimize

Measured Parameter System wise:

✓ : Available

✗ : Not Available

Sr No	Parameters	3 Phase 4Wire	3Phase 3Wire	1Phase 2Wire
1.	System Import Active Energy ¹	✓	✓	✓
2.	L1,L2,L3 Import Active Energy ¹	✓	✗	✗
3.	System Export Active Energy ¹	✓	✓	✓
4.	L1,L2,L3 Export Active Energy ¹	✓	✗	✗
5.	System Total Active Energy ¹	✓	✓	✓
6.	L1,L2,L3 Total Active Energy ¹	✓	✗	✗
7.	System Inductive Reactive Energy ¹	✓	✓	✓
8.	L1,L2,L3 Inductive Reactive Energy ¹	✓	✗	✗
9.	System Capacitive Reactive Energy ¹	✓	✓	✓
10.	L1,L2,L3 Capacitive Reactive Energy ¹	✓	✗	✗
11.	System Total Reactive Energy ¹	✓	✓	✓
12.	L1,L2,L3 Total Reactive Energy ¹	✓	✗	✗
13.	System Apparent Energy ¹	✓	✓	✓
14.	L1,L2,L3 Apparent Energy ¹	✓	✗	✗
15.	System Active Power (kW)	✓	✓	✓
16.	L1,L2,L3 Active Power (kW)	✓	✗	✗
17.	System Total Re-active Power (kVAr)	✓	✓	✓
18.	L1,L2,L3 Total Re-active Power (kVAr)	✓	✗	✗
19.	System Fundamental Re-active Power (kVAr) ²	✓	✓	✓
20.	L1,L2,L3 Fundamental Re-active Power (kVAr) ²	✓	✗	✗
21.	System Distorted Re-active Power (kVAr) ²	✓	✓	✓
22.	L1,L2,L3 Distorted Re-active Power (kVAr) ²	✓	✗	✗
23.	System Apparent Power (kVA)	✓	✓	✓
24.	L1,L2,L3 Apparent Power (kVA)	✓	✗	✗
25.	System Power Factor	✓	✓	✓
26.	L1,L2,L3 Power Factor	✓	✗	✗
27.	System Displacement Power Factor ²	✓	✓	✓
28.	L1,L2,L3 Displacement Power Factor ²	✓	✗	✗
29.	System Reactive Power Factor ²	✓	✓	✓
30.	L1,L2,L3 Reactive Power Factor ²	✓	✗	✗
31.	System LF Factor $\text{Sgn}Q(1-(P/S))^2$	✓	✓	✓
32.	L1,L2,L3 LF Factor $\text{Sgn}Q(1-(P/S))^2$	✓	✗	✗
33.	System Phase Angle	✓	✓	✓
34.	L1,L2,L3 Phase Angle	✓	✗	✗
35.	Current Demand	✓	✓	✓
36.	kVA Demand	✓	✓	✓
37.	Import kW Demand	✓	✓	✓
38.	Export kW Demand	✓	✓	✓
39.	Inductive Var Demand	✓	✓	✓
40.	Capacitive Var Demand	✓	✓	✓
41.	Max Current Demand	✓	✓	✓
42.	Max kVA Demand	✓	✓	✓
43.	Max Import kW Demand	✓	✓	✓
44.	Max Export kW Demand	✓	✓	✓
45.	Max Inductive Var Demand	✓	✓	✓
46.	Max Capacitive Var Demand	✓	✓	✓
47.	Run Hour	✓	✓	✓
48.	On Hour	✓	✓	✓
49.	Number of Interruptions	✓	✓	✓
50.	System Voltage	✓	✓	✓
51.	L1,L2,L3 Voltage	✓	✗	✗
52.	L12,L23,L31 Voltage	✓	✓	✗



Measure



Control



Record



Analyze



Optimize

Measured Parameter System wise:

✓ : Available

✗ : Not Available

Sr No	Parameters	3 Phase 4Wire	3Phase 3Wire	1Phase 2Wire
53.	System Voltage THD	✓	✓	✓
54.	L1-L2-L3 Voltage THD	✓	✓	✗
55.	System Current	✓	✓	✓
56.	L1-L2-L3 Current	✓	✓	✗
57.	System Current THD	✓	✓	✓
58.	L1-L2-L3 Current THD	✓	✓	✗
59.	Individual Harmonics VL1(Up to 31st Harmonics)	✓	✓	✓
60.	Individual Harmonics VL2 (Up to 31st Harmonics)	✓	✓	✗
61.	Individual Harmonics VL3 (Up to 31st Harmonics)	✓	✓	✗
62.	Individual Harmonics IL1(Up to 31st Harmonics)	✓	✓	✓
63.	Individual Harmonics IL2(Up to 31st Harmonic)	✓	✗	✗
64.	Individual Harmonics IL3(Up to 31st Harmonics)	✓	✓	✗
65.	Neutral Current (Calculated)	✓	✗	✗
66.	Frequency	✓	✓	✓
67.	RPM	✓	✓	✓
68.	Phase Sequence Indication	✓	✓	✗
69.	Current Reversal Indication	✓	✗	✓
70.	Phase (V-I) Absent Indication	✓	✗	✗
71.	Tariff Source 1 Energy Count	✓	✓	✓
72.	Tariff Source 2 Energy Count	✓	✓	✓
73.	Tariff Source 3 Energy Count	✓	✓	✓
74.	Tariff Source 4 Energy Count	✓	✓	✓
75.	Tariff Source 5 Energy Count	✓	✓	✓
76.	Tariff Source 6 Energy Count	✓	✓	✓
77.	Old Max A Demand ²	✓	✓	✓
78.	Old Max VA Demand ²	✓	✓	✓
79.	Old Max kW Import Demand ²	✓	✓	✓
80.	Old Max kW Export Demand ²	✓	✓	✓
81.	Old Max Var Inductive Demand ²	✓	✓	✓
82.	Old Max Var Capacitive Demand ²	✓	✓	✓
83.	Old System Import Active Energy ²	✓	✓	✓
84.	Old L1-L2-L3 Import Active Energy ²	✓	✗	✗
85.	Old System Export Active Energy ²	✓	✓	✓
86.	Old L1-L2-L3 Export Active Energy ²	✓	✗	✗
87.	Old System Inductive Reactive Energy ²	✓	✓	✓
88.	Old L1-L2-L3 Inductive Reactive Energy ²	✓	✗	✗
89.	Old System Capacitive Reactive Energy ²	✓	✓	✓
90.	Old L1-L2-L3 Capacitive Reactive Energy ²	✓	✗	✗
91.	Old System Apparent Energy ²	✓	✓	✓
92.	Old L1-L2-L3 Apparent Energy ²	✓	✗	✗
93.	Old Run Hour ²	✓	✓	✓
94.	Old On Hour ²	✓	✓	✓
95.	Old Number of Interruptions ²	✓	✓	✓
96.	Voltage VLN Unbalance	✓	✗	✗
97.	Voltage VLL Unbalance	✓	✓	✗
98.	Current Unbalance	✓	✓	✗

Note: 1. Energy on display is autoranging & unit for Energy parameters on modbus are dependent on CT PT ratio or unit selected by user.

2. Parameters are available only on modbus.



Measure



Control



Record



Analyze



Optimize

Ordering Information :

Ordering Information	MD00-	3	3	01	01	X	H	5	0000
Product Type	RISH MD 1340 - RJ12 CT Input - 100mA								
System Type	3 Phase (On site configurable as 1 / 3 Phase)								
Input voltage	100-500VLL 50/60Hz								
Input Current	CT-RJ12-100mA								
Output & Input Option	NONE					Z			
	RS485					M			
	RS485+2 Digital Input+2 RELAY Output					C			
	RS485+1 Digital Input+1 SO Output					S			
Auxiliary Supply	100 - 550V AC/DC								
Accuracy	Class 0.5S								

Order Code Example : MD00-330101CH50000

Rish MD1340 : Input RJ12 100mA, 100-500VLL 50/60Hz, Aux 100-550V AC/DC, with RS485+2 Digital Input+2 Relay output, Accuracy Class 0.5S

Rishabh Current Transformers with RJ12 Output



3 Phase RJ12 CT



3 Phase Nano CT with RJ12



Single Phase RJ12 CT



Quick Fix Module



Measure



Control



Record



Analyze



Optimize



Specifications may change without prior notice



Measure



Control



Record



Analyze



Optimize

RISHABH INSTRUMENTS LIMITED

Domestic (India): +91 253 2202099 | marketing@rishabh.co.in
International: +91 253 2202004/06/08/99 | global@rishabh.co.in
www.rishabh.co.in