

User Manual

Operating Instructions for RISH CT *Ducer* 50...750 A AC

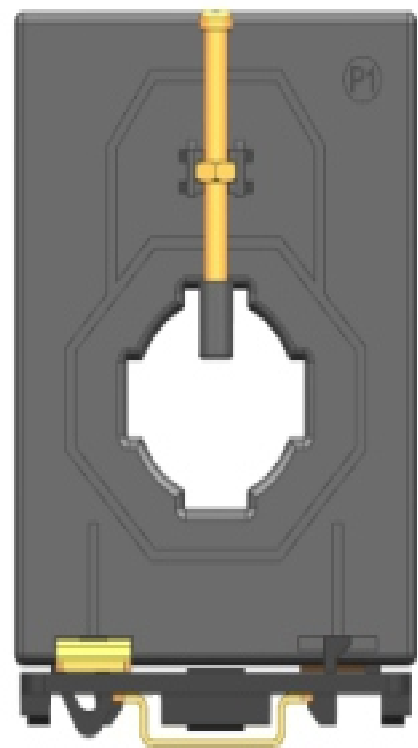
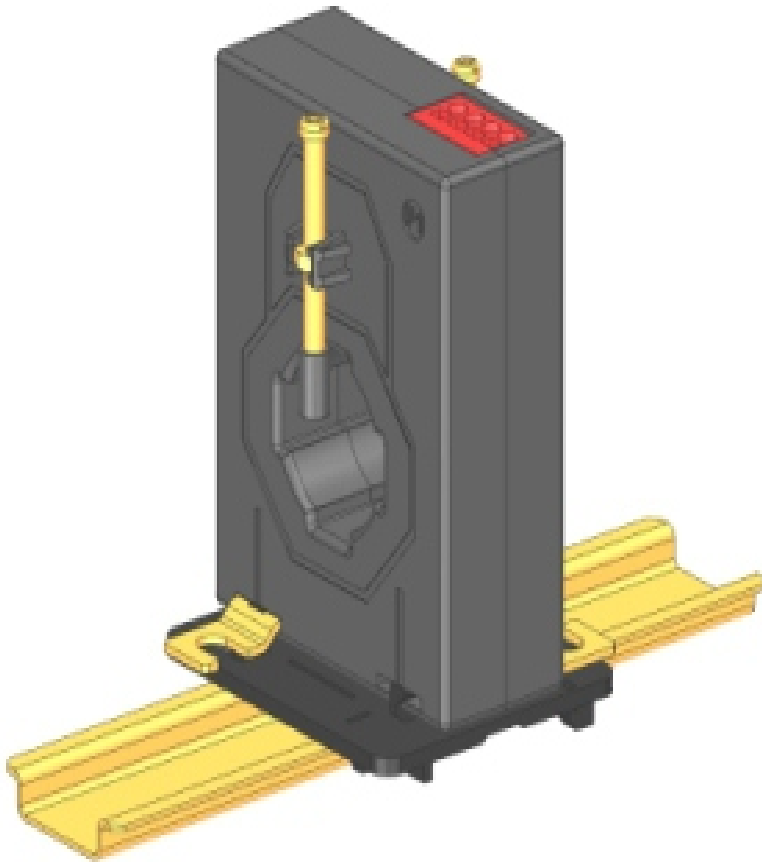

Rish CTDucer is a very reliable, efficient and robust current transformer for measurement of AC current. It provides 4 ... 20 mA or 0 ... 20mA DC output.

It is useful in :

- Data Monitoring & Network Analysis
- Measurement of non - sinusoidal and distorted networks

Features

- Two products in one - single device serves functionality of both current transformer as well as transducer
- Measurement of AC current for frequency 50/60Hz
- Provides proportional 4 ... 20 mA or 0 ... 20 mA DC output
- High output load resistance up to 1000 ohm
- Two models for True RMS and Average type measurement available
- Easy and safe electrical connection by means of spring clamp terminal

Technical Data

Input Parameter:

Measuring Range (In)	0 ... 300 A AC or 0 ... 750 A AC (Refer Model Info Table)
Input Frequency Range	50/ 60 Hz
Thermal Nominal Continuous Rated Current	1.2 x In

Output Parameter:

DC Current Output	4...20 mA , 0...20 mA
Max. Burden Resistance at Current Output	For U_H , R_B 1000 Ω For U_L , R_B 750 Ω R_B 1000 Ω ($U_L > 24V$ DC)
Current Limit Under Overload	< 30 mA
Voltage limit under $R = \infty$	≤ 25 V
Response Time	< 600ms
Max. Operating Voltage U_m	0.72 kV, U_{eff}

Auxiliary Power Supply Voltage:

Auxiliary Voltage (U_H or U_L)	U_H ...230 V AC, -50 / +15 %, 50/60 Hz (external protection via fuse 250 mA / 250 V, fast) OR U_L ...24 V DC, \pm 15 % (external protection via fuse 250 mA / 250 V, fast)
Current Consumption	For U_H , < 15 mA For U_L , < 50 mA

Accuracy:(Acc. to IEC/EN 60 688)

Reference Value	Output Span
Accuracy Class	\pm 0.5 %

Reference condition for accuracy:

Ambient temperature	23°C
Relative humidity	45-55 % rH
Measured quantity frequency	50 Hz(Sinusoidal waveform)
Supply voltage	For U_H , 230 V, 50Hz AC supply For U_L , 24 V DC
Burden resistance at output terminals	500 Ω

Additional Error:

Temperature Interference	\pm 0.3 % / 10°C
Influence of Variation	As per IEC/EN 60688 Standard
Influence of EMC (as per IEC 61236-1: 2020)	\pm 2 %

Safety:

Protection Class	IP20
Installation Category	III
Pollution Degree	2
Isolation Test Voltage (IEC 61010-1)	For U _H , 3 kV AC , 50 Hz, 60 Seconds Auxiliary supply vs Measuring output For U _H & U _L , 6.4 kV AC , 50 Hz, 60 Seconds Primary Conductor Vs Measuring Output Housing Vs Measuring output and Auxiliary supply

Environmental:

Nominal Range of use	0 ... <u>23°C</u> ... 70°C
Relative Humidity	0 ... 95 % rH without condensation
Storage Temperature	-40 ... 90°C
Altitude	Up to 2000 m
Max. Temperature of Primary Conductor	100° C

Ambient Tests:

Vibration	As per IEC 60068-2-6 Standard
Acceleration	± 2 g
Frequency range	10....150...10Hz,
Rate of frequency sweep	1 octave/minute
Number of cycles	10, in each of the three axes
Shock	As per IEC 60068-2-27 Standard
Acceleration	3 x 50g 3 shocks in each in 6 directions

Applicable Technical Standards :

Electromagnetic Compatibility	IEC 61326-1: 2020
Immunity	IEC 61000-4-2
	IEC 61000-4-3
	IEC 61000-4-4
	IEC 61000-4-6
	IEC 61000-4-8
Emission	CISPR 11
Safety	IEC 61010-1, 2010
Performance	IEC 60688, 2012

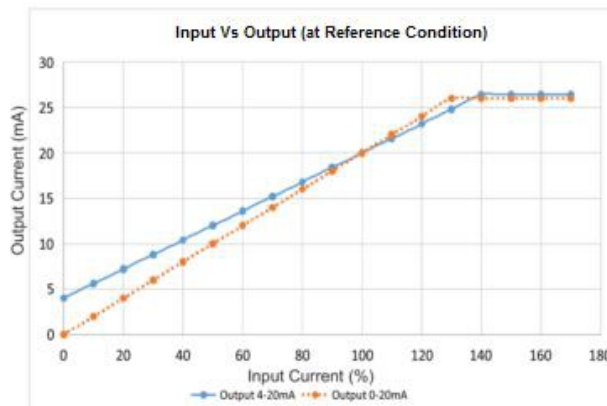

Electrical Connections for U_H

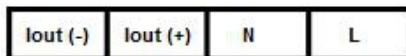

Spring clamp terminal

Connection cross sections: 0.08 ... 2.5 mm

Electrical Connections for U_L



Spring clamp terminal

Connection cross sections: 0.08 ... 2.5 mm

Connection Diagram for U_H

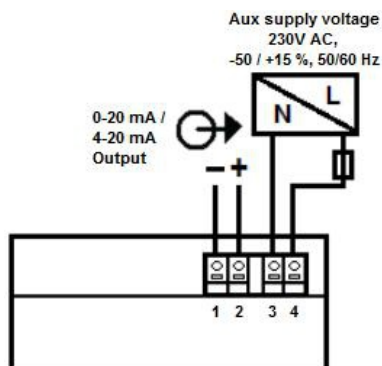

Connection Diagram for U_L

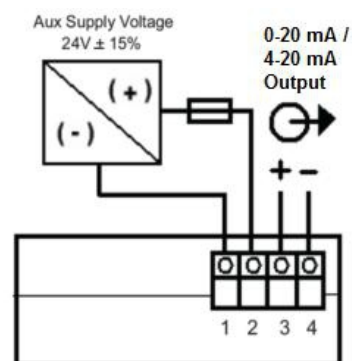

Dimensions :

Model 70 x 30 mm

Transformer width: 70 mm
Transformer height: 92 mm
Transformer depth: 44 mm

Bus bar: 30 x 10 mm
Round conductor: 28 mm

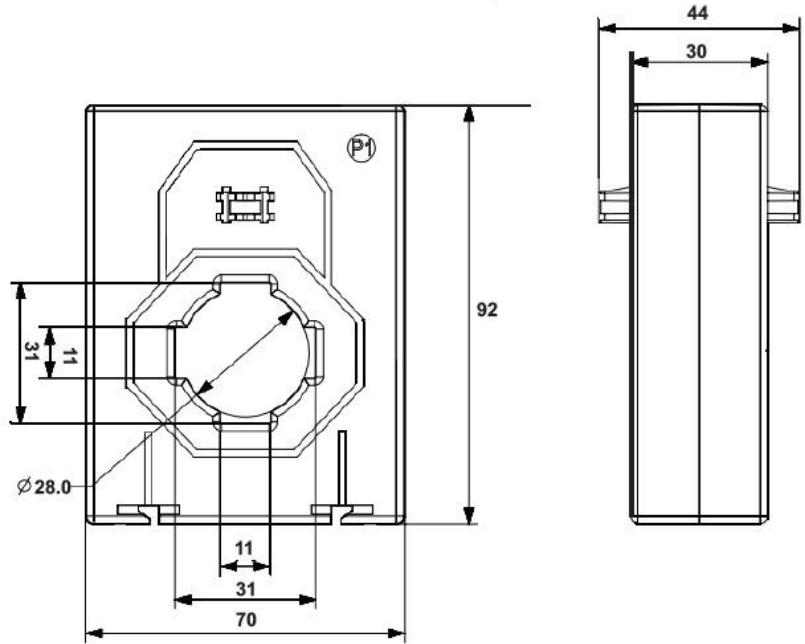

Model 90 x 40 mm

Transformer width: 90 mm
Transformer height: 115 mm
Transformer depth: 58 mm

Bus bar: 40 x 10 mm
Round conductor: 31.5 mm

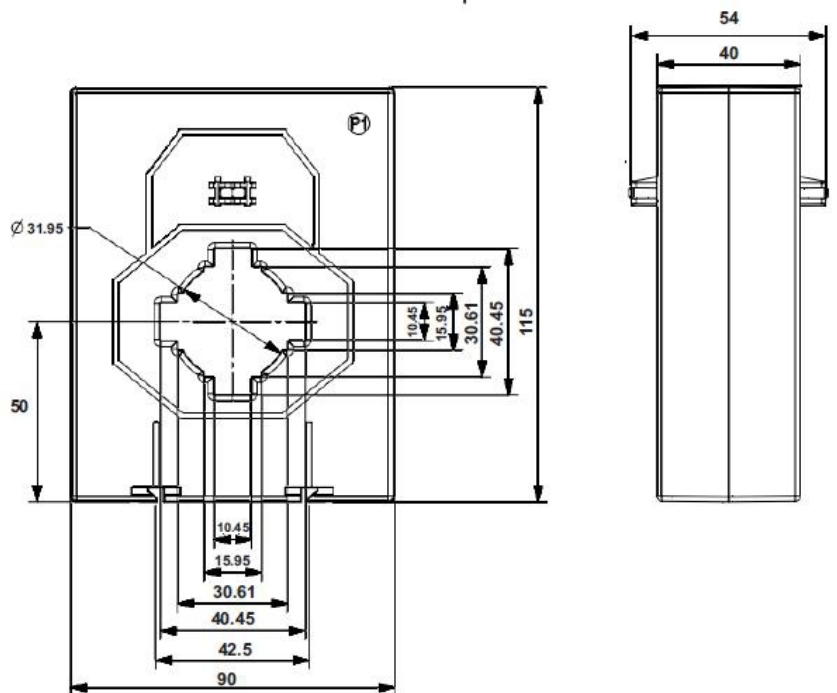

Rish CT Ducer, CT with Transducer options:

Type	Primary Current (AC)	Current Output (mA DC)
RISH CT Ducer 70 x 30mm * (TRMS or Average)	50	4 ... 20 mA or 0 ... 20 mA
	100	
	150	
	200	
	250	
	300	
RISH CT Ducer 90 x 40 mm (TRMS or Average)	50	4 ... 20 mA or 0 ... 20 mA
	100	
	150	
	200	
	250	
	300	
	400	
	500	
	600	
750		

* Available with lower Aux (U_L) Power supply only

How to do Connections:

RISH CTDucer comes with spring loaded connectors. Insert the screw driver in square shaped connector sockets and insert the wire in adjacent round hole and then remove the screw driver. Clamp inside the connector will hold the conductor of wire.

Mounting :

Various mounting options like wall mounting, cable mounting, busbar mounting, DIN rail mounting are available.

- a) For mounting on busbar use M4 screws and nuts to fit on busbar.
- b) DIN rail slots are provided on CTDucer
- c) For wall mounting use self lifting clamp strap provided with RISH CTDucer

Scope of supply :

- 1) RISH CTDucer : 1 nos.
- 2) Test certificate : 1 nos.
- 3) Self lifting clamp strap: 2 nos.
- 4) Operating instruction manual.

NOTE



RISHABH

Measure, Control & Record with a Difference

RISHABH
INSTRUMENTS

RISHABH INSTRUMENTS LTD.

F-31, M.I.D.C., Satpur, Nashik 422 007, India.

Tel. : +91 253 2202162, 2202202,

Fax : +91 253 2351064

Email : marketing@rishabh.co.in

www.rishabh.co.in