



# RISH DELTA ENERGY NX

## With Touch Key



Measure



Control



Record



Analyze



Optimize

RISH Delta Energy NX measures important electrical parameters in 3phase 4wire, 3phase 3wire, 1phase 2wire and 1phase 3wire network. It displays many parameters at a glance. It measures electrical parameters like Active / Reactive / Apparent energy, power and all basic parameter. The instrument has one optional built in Relay output which can be configured as pulse output for energy measurement, as well as limit output. Optional MODBUS RTU over RS-485 is built in for remote monitoring and configuration.

### Product Features:

#### Energy as per IEC 62053-21 & IEC 61557-12:

- ▶ RISH Delta Energy NX is available in Accuracy Class 1
- ▶ Active Energy accuracy Class 1 as per 62053-21 & 61557-12
- ▶ Independent Import and Export Energy counter. Active energy (kWh), Reactive energy (kVArh), Apparent energy (kVAh) measurement.

#### THD Measurement:

- ▶ The instrument measures per phase and system THD up to 31st harmonics for voltage and current.

#### True RMS Measurement

- ▶ The instrument measures distorted waveform up to 31st harmonic.

#### On site programmable PT/CT ratios:

- ▶ It is possible to program primary, secondary of external potential transformer (PT) & primary, secondary of external current transformer (CT) via front panel keys and MODBUS.

#### Limit (Alarm) or Pulse Output (Optional)

- ▶ Available in Potential Free output
- ▶ Configurable as pulse output which can be used to drive an external counter for energy measurement.
- ▶ Configurable as limit (alarm) switch.

#### MODBUS (RS485) Output: (Optional)

- ▶ RS485 output enables the instrument to transmit all the Measured parameters over standard MODBUS protocol
- ▶ The instrument can be configured locally via front panel keys as well as MODBUS communication.

#### Storage of parameters possible

- ▶ The instrument stores minimum and maximum values of System Voltage, System Current. Also Run Hour, ON Hour and number of AUX interrupts are stored.

#### Energy Count Storage

- ▶ In case of power failure, the instrument memorizes the last energy count. The instrument updates the energy counter in the non-volatile memory.

#### Impulse LED

- ▶ Impulse LED on the front of the instrument is useful for checking the accuracy of energy measured by the instrument.

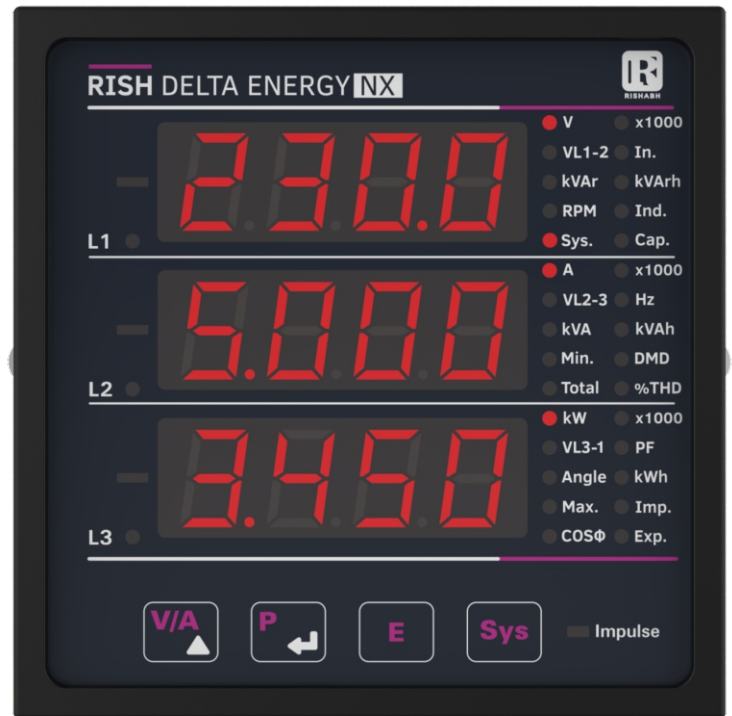

#### Display:

- ▶ 3 Line, 4 Digit bright Red LED display and indication LEDs
- ▶ Display can be configured for automatic scrolling of parameters or manual scrolling through 4 keys as per requirement and application of user.

#### Demand

- ▶ RISH Delta Energy NX integrates demand value for Active Power (kW), Apparent Power (kVA) and Current (A).
- ▶ The demand integration time can be configured from 1min to 60min

#### Compliance to International Safety standards

- ▶ Compliance to International Safety standard IEC 61010-1- 2018

#### EMC Compatibility

- ▶ Compliance to International standard IEC 61326



### Dimensions Details:

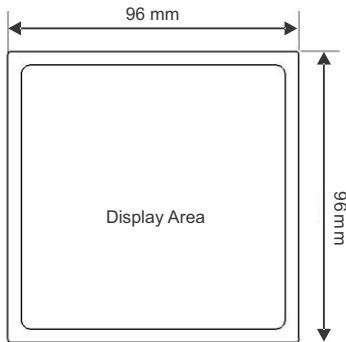

Front View

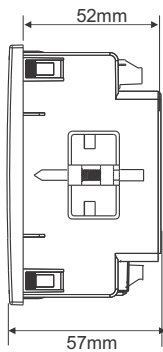

Side View

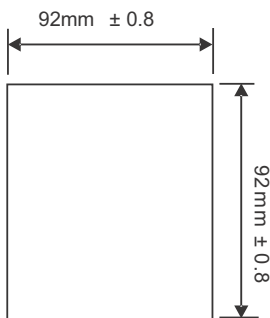

Panel Cutout

#### Wiring Guidelines

Solid with Pin type lugs (sq. mm)	1 to 2.5
Stranded with pin types lugs (sq. mm)	1 to 2.5
Torque value (Nm)	
1. Aux and Voltage terminals	0.5 to 0.6
2. Current Terminals	0.4 to 0.5
3. RS485 and Relay terminals	0.3 to 0.4
Length available for lug entry in terminal (mm)	9.5

### Technical Specifications:

#### Input Voltage:

Nominal input voltage (AC RMS) programmable on site.	100VLL to 500VLL (57.5VLLN to 288.67VLLN)
System PT primary values	100VLL to 1200kVLL programmable on site. (1000MVA maximum power per phase) (1200kVLL when CT primary ≤ 1002A)
Max continuous input voltage	120% of nominal value
Overload Indication	"-ol-" >121% of Nominal value
Nominal input voltage burden	< 0.3VA approx. per phase (at nominal 240V)
Overload Withstand:	2 x rated value for 1 second, repeated 10 times at 10 second intervals

#### Input Current:

Nominal input current	1A / 5A onsite programmable
System CT primary values	From 1A to 9999A (1000 MVA maximum power per phase) (9999A when PT primary ≤ 120kVLL)
Max continuous input current	120% of nominal value
Overload Indication	"-ol-" >121% of Nominal value
Nominal input current burden	< 0.3VA approx. per phase
Overload Withstand:	20 x rated value for 1 second, repeated 5 times at 5 minute intervals

#### Auxiliary Supply:

Higher Auxiliary supply range	60-300V AC/DC (230V AC/DC nominal)
Lower Auxiliary supply range	20-60V AC/DC (24V AC / 48V DC nominal)
Aux Supply frequency	45 to 65 Hz range
Auxiliary Supply burden	< 6VA approx.

#### Operating Measuring Ranges:

Current (Energy Measurement)	1 to 120% of nominal value
Starting current :	As per Standard IEC 62053-21 (Class 1)
Voltage	19VLL to 600VLL (11VLLN to 346VLLN)
Power Factor	0.5 Lag ... 1 ... 0.5 Lead
Frequency	40Hz to 70Hz

#### Reference Conditions for Accuracy

Reference temperature	23°C +/- 2°C
Influence of temperature	0.015%/°C for Voltage & 0.025%/°C for Current
Input Waveform	Sinusoidal (distortion factor 0.005)
Input frequency	50/60 Hz ± 2%
Auxiliary supply frequency	50/60 Hz ± 1%
Voltage Range	20 ... 120% of nominal value
Current Range	10 ... 120% of nominal value
Total Harmonic distortion	40% (up to 31st Harmonics)
Voltage range for THD	50% ... 100% of nominal value
Current range for THD	20% ... 100% of nominal value

#### Accuracy (Energy)

Active Energy	Class 1 as per IEC 62053-21 & IEC 61557-12
Apparent Energy	Class 1 as per IEC 61557-12
Reactive Energy	Class 2 as per IEC 62053-23 & IEC 61557-12



Measure



Control



Record



Analyze



Optimize

### Electrical Connection:

#### Network Types :

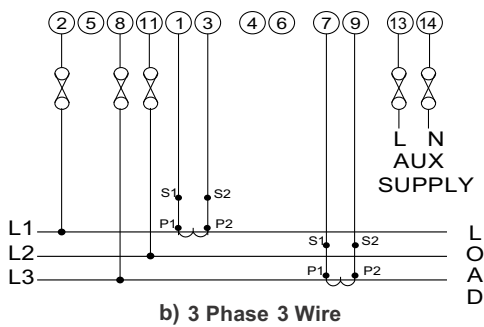
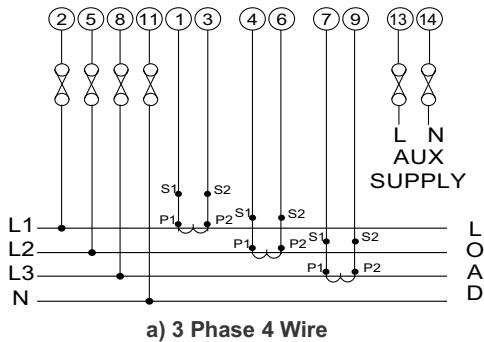

**Note:** L2 phase needs to be connected in terminal 11 instead of terminal 5 only for 3 Phase 3 Wire connections.

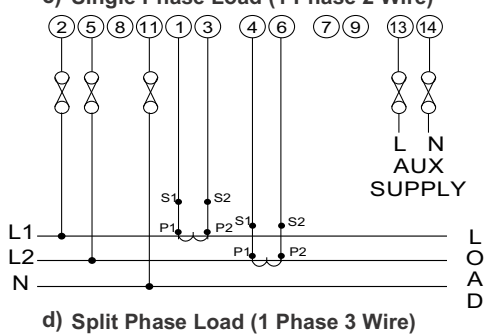
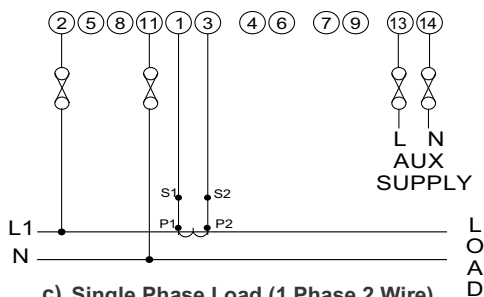

It is recommended that the wires used for connections to the instrument should have lugs crimped at the end. That is, the connections should be made with Lugged wires for secure connections.

### Technical Specifications:

#### Accuracy

Voltage	± 0.5% of Nominal value
Current	± 0.5% of Nominal value
Frequency	± 0.1% of mid frequency
Active Power	± 1% of Nominal value
Re-Active Power	± 1% of Nominal value
Apparent Power	± 1% of Nominal value
Power Factor/ angle	±2°
THD (Voltage / Current)	±3%

#### Display update rate:

Response time to step input 1 sec approx.

#### Applicable Standards:

EMC IEC 61326-1 :Table 2

Safety IEC 61010-1-2018 use

IP for water & dust IEC 60529

#### Isolation:

Pollution degree: 2

Installation category: III

High voltage test

Input + AUX Vs Surface 4kV RMS, 50Hz, 1min

Input + AUX Vs Remaining Circuit 3.3kV RMS, 50Hz, 1min

MODBUS Vs Relay 2kV RMS, 50Hz, 1min

#### Environmental

Operating temperature -20 to +70°C

Storage temperature -25 to +75°C (Tested as per IEC 60688)

Relative humidity 0... 95% RH (non condensing)

Warm up time Minimum 3 minute

Shock (As per IEC60068-2-27) Half sine wave, Peak acceleration 30gn (300 m/s<sup>2</sup>), duration 18ms.

Vibration 10 ... 150 ...10 Hz, 0.15mm amplitude

Number of Sweep cycles 10 per axis

Enclosure IP20 (Terminal side) and IP54 (Front side)

Altitude 2000

#### Installation:

Mechanical Housing Lexan 940 (polycarbonate), Flammability Class V-0 acc. to UL 94, self extinguishing, non dripping, free of halogen

Mounting Position Panel Mounted (96X96)

Connection Element Conventional screw type terminal with indirect wire terminals (Screw Torque: 0.5N.m)

Connection Terminal 4mm<sup>2</sup> solid or 2.5mm<sup>2</sup> stranded cable

Weight 250 Gram Approx.

#### Interfaces

Impulse Led For Energy testing

Relay (Optional) 250 VAC, 5A AC  
30VDC, 5A DC

MODBUS (Optional) RS485, max.1200m.  
Baud rate: 2.4k, 4.8k, 9.6k, 19.2k, 38.4k, 57.6k bps (Response time < 200ms)



Measure



Control



Record



Analyze



Optimize

### Measured Parameter System wise:

√ : Available

x : Not Available

Sr. No.	Parameter	3 Phase 4 Wire	3 Phase 3 Wire	1 Phase 2 Wire	1 Phase 3 Wire
1	System Volts	√	√	√	√
2	System Current	√	√	√	√
3	Voltage L1	√	x	x	√
4	Voltage L2	√	x	x	√
5	Voltage L3	√	x	x	x
6	Voltage L12	√	√	x	√
7	Voltage L23	√	√	x	x
8	Voltage L31	√	√	x	x
9	Current L1	√	√	x	√
10	Current L2	√	√	x	√
11	Current L3	√	√	x	x
12	Frequency	√	√	√	√
13	System Active Power	√	√	√	√
14	Active Power L1	√	x	x	√
15	Active Power L2	√	x	x	√
16	Active Power L3	√	x	x	x
17	System Re-active Power	√	√	√	√
18	Re-active Power L1	√	x	x	√
19	Re-active Power L2	√	x	x	√
20	Re-active Power L3	√	x	x	x
21	System Apparent Power	√	√	√	√
22	Apparent Power L1	√	x	x	√
23	Apparent Power L2	√	x	x	√
24	Apparent Power L3	√	x	x	x
25	System Phase Angle	√	√	√	√
26	System Power Factor	√	√	√	√
27	Power Factor L1	√	x	x	√
28	Power Factor L2	√	x	x	√
29	Power Factor L3	√	x	x	x
30	Phase Angle L1	√	x	x	√
31	Phase Angle L2	√	x	x	√
32	Phase Angle L3	√	x	x	x
33	Import Active Energy	√	√	√	√
34	Export Active Energy	√	√	√	√
35	Inductive Re-active Energy	√	√	√	√



Measure



Control



Record



Analyze



Optimize

### Measured Parameter System wise:

√ : Available      x : Not Available

Sr. No.	Parameter	3 Phase 4 Wire	3 Phase 3 Wire	1 Phase 2 Wire	1 Phase 3 Wire
36	Capacitive Re-active Energy	√	√	√	√
37	Apparent Energy	√	√	√	√
38	RPM	√	√	√	√
39	Min and Max System Voltage	√	√	√	√
40	Min and Max System Current	√	√	√	√
41	Run Hour	√	√	√	√
42	On Hour	√	√	√	√
43	Number of Interruptions	√	√	√	√
44	Current Demand	√	√	√	√
45	kVA Demand	√	√	√	√
46	Import kW Demand	√	√	√	√
47	Export kW Demand	√	√	√	√
48	Max Current Demand	√	√	√	√
49	Max kVA Demand	√	√	√	√
50	Max Import kW Demand	√	√	√	√
51	Max Export kW Demand	√	√	√	√
52	Neutral Current	√	x	x	√
53	Max Neutral Current	√	x	x	√
54	%THD Voltage L1	√	√	x	√
55	%THD Voltage L2	√	x	x	√
56	%THD Voltage L3	√	√	x	x
57	%THD Current L1	√	√	x	√
58	%THD Current L2	√	x	x	√
59	%THD Current L3	√	√	x	x
60	System Voltage THD	√	√	√	√
61	System Current THD	√	√	√	√
62	Min and Max Import Active Power*	√	√	√	√
63	Min and Max Export Active Power*	√	√	√	√
64	Min and Max Inductive Re-active Power*	√	√	√	√
65	Min and Max Capacitive Re-active Power*	√	√	√	√
66	Min and Max Apparent Power*	√	√	√	√
67	Min and Max Line Voltage*	√	√	√	√
68	Min and Max Line Current*	√	√	√	√

\*Note - Line and System parameters Min Max values are shown on Modbus only.



Measure



Control



Record



Analyze



Optimize

Ordering Information

Product Code: DE30 – 3 – 3 – 01 – 02 – X – X – 5 – 0000

RISH DELTA ENERGY NX

Z – None  
R – RS485 + 1 Relay Output

H: 60-300V AC/DC  
L: 20-60V AC/DC

Order Code Example: **DE30-330102RH50000**  
RISH Delta Energy NX with Higher Auxiliary Supply, RS485 and 1 Relay Output



Measure



Control



Record



Analyze



Optimize



RISHABH



Measure



Control



Record



Analyze



Optimize

## RISHABH INSTRUMENTS LIMITED

Domestic (India): +91 253 2202099 | [marketing@rishabh.co.in](mailto:marketing@rishabh.co.in)  
International: +91 253 2202004/06/08/99 | [global@rishabh.co.in](mailto:global@rishabh.co.in)  
[www.rishabh.co.in](http://www.rishabh.co.in)