

OPERATING MANUAL



EarthLite

Digital Earth Resistance Tester

TABLE OF CONTENTS

Chapter 1. Safety Information

- 1.1 General Safety Warnings
- 1.2 Live Earth Safety Precautions
- 1.3 Voltage Measurement Categories (CAT III / CAT IV, Pollution Degree 2)
- 1.4 Test Leads and Connections
- 1.5 Safety, Hazard and Warning Symbols
- 1.6 Battery Safety – AAA Alkaline Cells Only

Chapter 2. Introduction & Applications

- 2.1 Product Overview
- 2.2 Typical Applications
- 2.3 Features & Benefits
- 2.4 Supplied Accessories
- 2.5 Optional Accessories

Chapter 3. Instrument Overview

- 3.1 Mechanical Design & Enclosure
- 3.2 Front Panel & Keypad Description
- 3.3 Display Layout – Symbols and Indicators
- 3.4 Auto Power-Off and Back-light

Chapter 4. Operation

- 4.1 Power ON/OFF and Battery Indication
- 4.2 Mode Selection
 - 4.2.1 2P Earth Resistance Mode
 - 4.2.2 3P Earth Resistance Mode
 - 4.2.3 Earth Voltage Mode
- 4.3 Range Selection (20 Ω / 200 Ω / 2000 Ω)
- 4.4 Test Frequency and Measurement Time
- 4.5 HOLD Function
- 4.6 SAVE / LOAD Function (50 Readings Memory)
- 4.7 Display Back-light Operation

Chapter 5. Set-Up and Configuration

- 5.1 Site Preparation and Soil Conditions
- 5.2 Interference & Noise Rejection Guidelines
- 5.3 Memory Handling (Save, Recall, Clear)
- 5.4 Recommended Test Lead Layouts

Chapter 6. Measurement Procedures

- 6.1 Earth Voltage Measurement
- 6.2 Two-Pole (2P) Earth Resistance Measurement
- 6.3 Three-Pole (3P) Earth Resistance Measurement
- 6.4 Using Existing Ground as Reference (Simple Method)
- 6.5 Interpreting Measurement Results

Chapter 7. Calibration & Performance

- 7.1 Measurement Principle (Ohm's Law – V/I)
- 7.2 Earth Resistance Accuracy & Reference Conditions
- 7.3 Earth Voltage Accuracy & Reference Conditions
- 7.4 Test Current Injection & Test Signal Frequency
- 7.5 Open Circuit, Lead Error and Overload Indications

Chapter 8. Specifications

- 8.1 Electrical Specifications
 - 8.1.1 Earth Resistance (2P/3P)
 - 8.1.2 Earth Voltage (up to 450 V AC)
- 8.2 Environmental Conditions
- 8.3 Mechanical Specifications
- 8.4 Safety & EMC Standards and Certifications

Chapter 9. Maintenance & Service

- 9.1 General Maintenance & Cleaning
- 9.2 Battery Replacement Procedure
- 9.3 Storage & Transport
- 9.4 Service, Repair and Warranty

Chapter 10. Annexures

- 10.1 Display Content Reference Table
- 10.2 Quick Connection Diagrams (2P / 3P / Earth Voltage)
- 10.3 Accessories List
- 10.4 Glossary of Terms
- 10.5 Revision History

CHAPTER 1

SAFETY INFORMATION

This section provides essential guidelines to ensure safe handling and operation of the Digital Earth Resistance Tester. Read all instructions carefully before using the instrument. Failure to follow these precautions may result in electric shock, damage to equipment, inaccurate measurements, or personal injury

The safety information in this manual is intended to complement, not replace, local site safety regulations and engineering practices

Note: The term earth used in this manual refers to ground in international terminology

1.1 General Safety Warnings

- The instrument must only be operated by qualified and trained personnel familiar with grounding systems and electrical measurement procedures.
- Use the instrument only for its intended functions—earth resistance and earth voltage testing. Any unauthorized use may compromise internal protection systems.
- Inspect the instrument and test leads before use. Do not use if any damage, cracks, exposed conductors, or insulation wear is present.
- Always verify test leads and terminal connections are secure before applying power or starting measurements.
- Avoid touching test leads, electrodes, clamps, or the installation under test while a measurement is in progress.
- Do not operate the tester if wet or in explosive or flammable environments.
- Ensure the correct mode of selection before performing a test.
- Never leave the instrument connected to a live system unattended.
- Disconnect the tester after completing each measurement and before adjusting any test probes or stakes.
- Do not apply more than the rated maximum voltage between any terminals of the instrument.
- Do not attempt to open, modify, or repair the instrument yourself. Servicing must be performed by authorized personnel only.

1.2 Electrical Shock & Live Earth Precautions





- Always assume that any earth electrode may become energized due to electrical faults or soil potential rise.
- When testing in energized sites (industrial, substations), use appropriate PPE, including insulated gloves, insulated footwear, and rubber safety mats.
- Isolate the grounding system under test whenever possible before measurement.
- Never touch electrodes or test leads during testing, especially when measuring earth voltage.
- Stop the test immediately if abnormal noise, vibration, heat, or odor are detected

1.3 Environmental Safety Conditions

To ensure accurate operation and safe performance:

- Operating Temperature: 0°C to 45°C
- Storage Temperature: -5°C to 60°C
- Relative Humidity: < 85% (non-condensing)
- Pollution Degree: Pollution Degree 2 environments only
- Avoid operating in direct sunlight for prolonged periods.
- If the unit becomes moist or wet, turn off immediately and allow it to dry completely before reuse.
- Keep the unit free from dust, chemicals, corrosive vapors, or mechanical shock.

1.4 Safety Symbols Used on the Instrument

Symbol	Meaning
	Caution: Warns the user of potential hazards and the need to follow instructions to avoid damage or injury.
	The equipment is protected by double insulation.
	Do not dispose of the instrument with normal household waste.
	Indicates conformity with applicable EU Directives.
	Indicates the common reference point of the device and the return path for electrical current.

1.5 Battery Safety (AAA Alkaline)

- Use only AAA alkaline batteries.
- Insert with correct polarity.
- Do not mix old and new batteries.
- Remove batteries for long-term storage.
- Do not short, heat, or dispose of in fire.

1.6 Protection & Standards

The instrument complies with::

- IEC 61010-1 (Safety)
- IEC 61557-1 & 61557-5 (Earth testing)
- IEC 61326-1 (EMC)
- Measurement Category: CAT III 600V / CAT IV 300V

Warning: Never operate the instrument beyond its rated measurement categories or voltage limits.

CHAPTER 2

INTRODUCTION & APPLICATIONS

The Digital Earth Resistance Tester is a portable instrument designed for accurate earth voltage and earth resistance measurement using two-pole and three-pole test methods. The instrument provides reliable testing of grounding systems in residential, commercial, industrial, and utility installations, ensuring electrical safety and performance of earth electrodes and grounding networks.

The instrument is compact, rugged, and battery-powered, making it ideal for field measurements. With its intuitive user interface, large LCD display, and high measurement accuracy, it is suitable for daily professional use by electricians, maintenance engineers, contractors, and inspection agencies.

For best operation, all safety instructions must be read and understood before using the tester.

2.1 Product Overview

The Digital Earth Resistance Tester is a high-performance instrument developed for verifying the integrity of grounding and earthing systems. It measures the resistance of buried electrodes by injecting test current into the soil and calculating the resulting voltage drop using Ohm's Law.

Key capabilities include:

- Earth Resistance Measurement (2P & 3P methods)
- Earth Voltage Measurement (up to 450V AC)
- Selectable measurement ranges of 20Ω / 200Ω / 2000Ω
- Noise and interference rejection for stable readings in challenging field conditions
- High-contrast LCD display with HOLD and Back-Light features
- Battery-powered operation using AAA alkaline cells

The instrument is designed to comply with IEC safety and EMC standards, offering dependable performance for ground verification and certification tasks.

2.2 Typical Applications

The tester is suitable for a broad set of grounding and earthing evaluations, including:

- Testing residential, commercial, and industrial earthing installations
- Inspection and validation of earth pits and electrode systems
- Maintenance of transformer and generator grounding networks
- Testing grounding of communication shelters, data centers, and towers
- Assessing neutral-earth voltage problems and identifying unsafe earth potentials
- Routine testing during electrical installation audits and safety inspections

2.3 Feature & Benefits

- **Two-Pole Earth Resistance Measurement**

Enables quick and convenient measurement of earth resistance using only two terminals, suitable for checking earth pits without disconnecting existing wiring.
- **Three-Pole Earth Resistance Measurement**

Provides accurate earth resistance measurement using auxiliary electrodes (P & C stakes) for precise site testing as per standard testing methodology.
- **High Interference & Noise Rejection (up to 50 Vpp)**

Advanced filtering and signal processing ensure reliable and stable measurements even in high electrical noise environments, such as live industrial sites.
- **Earth Voltage Measurement (Up to 450 V AC)**

Measures ground-to-neutral voltage to verify installation safety, detect leakage, and assess system health before conducting earth resistance testing.
- **Backlight LCD Display**

Bright backlit display ensures clear visibility of readings in low-light conditions, including basements and outdoor night testing.
- **Display HOLD Function**

Allows users to freeze and review stable readings without maintaining probe contact, improving convenience and operational safety.
- **Built-in Memory (Storage of 50 Readings)**

Stores up to 50 test results, enabling easy review, analysis, and documentation without the need for repeated testing.
- **Overload Protection (OL Indication)**

Provides automatic protection up to 1.2 times the measuring range for 10 seconds, safeguarding the instrument against accidental over-range voltage or current exposure.
- **Battery Level Indicator**

Real-time battery status display helps prevent unexpected shutdowns and supports effective planning during field operations.
- **Rugged Handheld Design**

Compact, portable, and ergonomically designed enclosure with a firm grip, suitable for demanding field environments.
- **Runs on Standard AAA Alkaline Batteries**

Powered by 6 x 1.5 V AAA alkaline batteries, ensuring easy availability and extended operating time in the field.
- **Auto Power-Off Function**

Automatically switches the instrument OFF after 2 minutes of inactivity to conserve battery life.

2.4 Supplied Accessories

Sr. No.	Item Description	Specification / Details	Quantity
1	Digital Earth Resistance Tester	Instrument unit	1 Nos
2	Earth spikes / ground stakes	10 mm diameter × 250 mm length	2 Nos.
3	Test lead – red	20 m length	1 Nos
4	Test lead – yellow	10 m length	1 Nos
5	Test lead – green	10 m length	1 Nos
6	Simple test lead with alligator clips	Double plug × 1, Single plug × 1	1 Nos
7	AAA alkaline batteries	1.5 V	6 Nos
8	Carrying bag	Protective case	1 Nos
9	User manual	Instruction manual	1 Nos

2.5 Optional Accessories

Sr. No.	Item Description	Specification / Details	Quantity
1	Earth spikes	10 mm diameter × 450 mm length	2 Nos.
2	Hammer	Suitable for driving earth spikes	1 Nos

CHAPTER 3

INSTRUMENT OVERVIEW

The Digital Earth Resistance Tester is designed with a rugged and ergonomic structure suitable for field environments. The instrument provides intuitive operation through a clearly labelled keypad and a high-visibility digital LCD display with status indicators. All electrical measurement terminals are positioned on the top side of the enclosure to ensure safe and convenient test lead connections.

3.1 Mechanical Design & Enclosure

- The instrument features durable ABS housing designed to withstand rough handling and outdoor testing conditions.
- The enclosure is lightweight and compact, enhancing portability for field engineers.
- A rubber-protected outer frame absorbs mechanical shock during transport.
- The instrument includes a tilt stand at the rear side to enable angled viewing during testing.
- Designed for IP-rated dust and splash resistance* (based on environmental conditions and proper use).
- Battery compartment located at the rear side with a secure screw-lock cover for safe access to AAA cells.

Note: Do not immerse the device in water or operate in heavy rainfall without proper protection.

3.2 Front Panel & Keypad Description

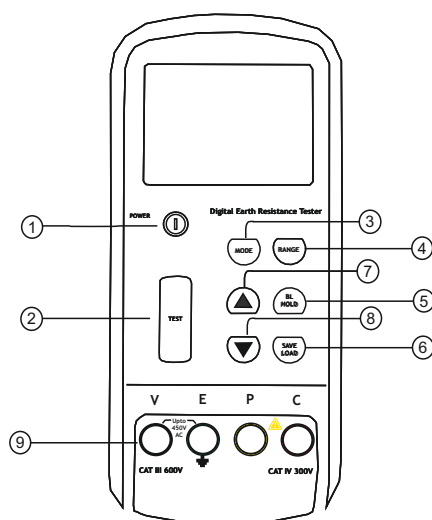

Sr. No.	Button / Terminal Name	Function Description
1	Power Button	Turns the instrument ON/OFF. Automatically powers down after a period of inactivity to conserve battery life.
2	Test Button	Initiates the earth resistance measurement when pressed.
3	Mode Button	Selects the measurement mode, such as Earth Resistance (Ω) or Earth Voltage (V).
4	Range Button	Manually selects the measurement range or switches between auto-range and manual modes.
5	BL Button	Activates or deactivates the LCD backlight for improved visibility in low-light environments
6	Load / Save Button	Short press: Save reading. Long press: Load stored readings.
7	Up Button	Navigates upward through stored readings.
8	Down Button	Navigates downward through stored readings.
9	Terminals (V, E, P, C)	Measurement terminals: E – Earth electrode under test, P – Potential probe, C – Current probe, V – Voltage measurement terminal.

3.3 Display Layout – Symbols and Indicators

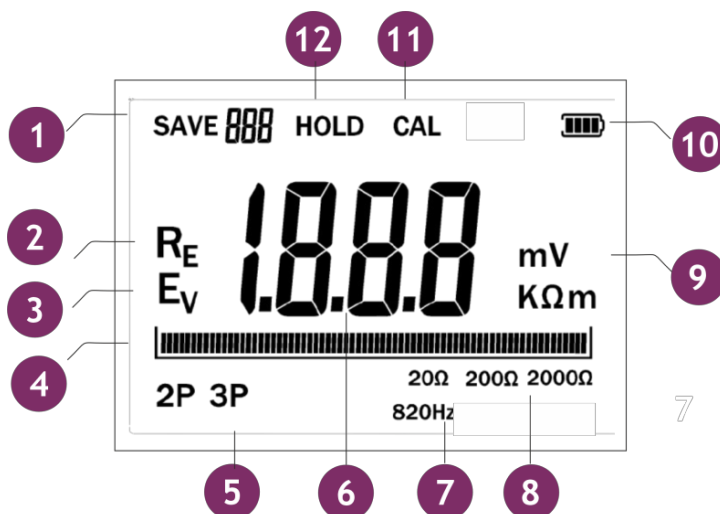

Sr. No.	Display Symbol / Indicator	Description
1	SAVE / LOAD Indication	Indicates saving or recalling of stored measurement data
2	Earth Resistance (R_E)	Indicates earth resistance measurement mode
3	Earth Voltage (E_V)	Indicates earth voltage measurement mode
4	Analog Bar Graph	Provides a visual representation of the measured value
5	Measurement Mode & Probe Method	Displays selected test method (2P or 3P measurement)
6	Measured Value Display	Main digital display showing measured resistance or voltage
7	Test Signal Frequency	Indicates test signal frequency (e.g., 820 Hz)
8	Selected Measurement Range	Shows selected resistance range (20 Ω / 200 Ω / 2000 Ω)
9	Measurement Units	Displays measurement units (mV, kΩ, Ω)
10	Battery Status Indicator	Indicates remaining battery level
11	Calibration Mode (CAL)	Indicates instrument is in calibration mode
12	Display HOLD Indication	Indicates the displayed reading is held/frozen

3.4 Auto Power-Off and Back-light

- The instrument includes an auto power-off function to conserve battery life.
- If no key operation occurs for approximately 2 minutes, the instrument automatically shuts down.
- The back-light function may be activated by pressing the HOLD / BL key.
- The back-light automatically turns off after approximately 15 seconds to prevent battery drain.

Note: Auto power-off is disabled during an active measurement cycle.

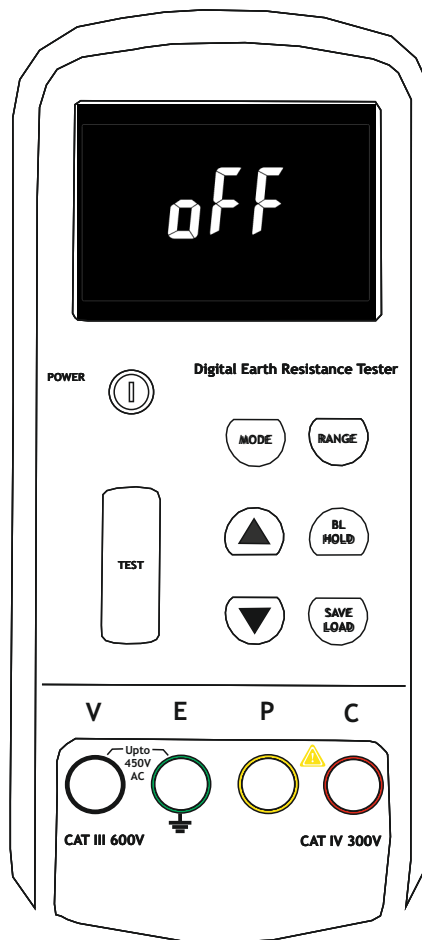

CHAPTER 4

OPERATION





This chapter describes the basic operation of the Digital Earth Resistance Tester, including power control, mode selection, range selection, display functions, and memory operations.

4.1 Power ON/OFF and Battery Indication

- Press the POWER key once to switch the instrument ON.
- On power-up, the LCD performs a self-test and displays the Earth Resistance mode.
- The battery status indicator appears on the display. Replace batteries when a low-battery indication is shown.
- Press the POWER key again to switch the instrument OFF.

Note: The instrument automatically powers OFF after approximately 2 minutes of inactivity to conserve battery life.

Battery Indication :

Battery Icon	Battery Voltage Level	Status
	Battery voltage > 8.2 V	100% to 80%
	7.9 V – 8.2 V	80% to 60%
	7.5 V – 7.9 V	60% to 40%
	7.0 V – 7.5 V	40% to 20%
	6.8 V – 7.0 V	20% to 0%

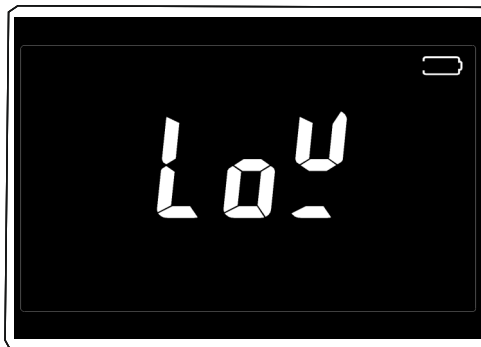

4.2 Mode Selection

- Use the MODE key to cycle through available test modes:
2P → 2 Pole Resistance
3P → 3 Pole Resistance
EV → Earth Voltage
- The currently selected mode is shown on the LCD via symbols and labels.
- Always ensure proper test lead connections before starting a measurement.

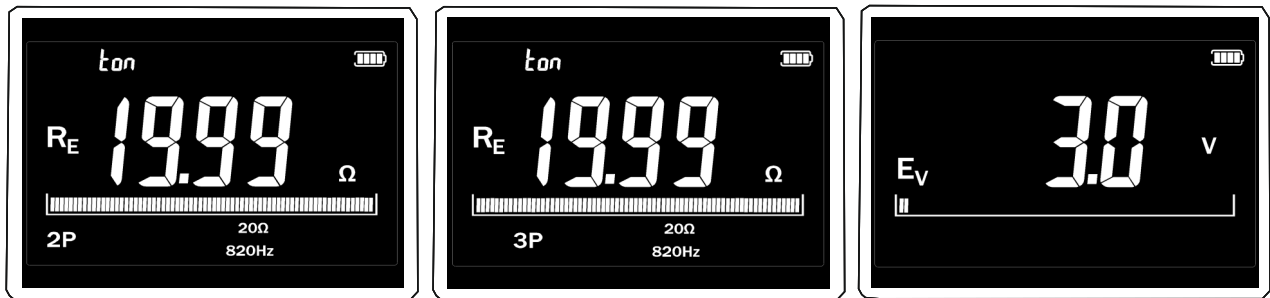

4.3 Range Selection (20 Ω / 200 Ω / 2000 Ω)

- Press the RANGE key to select the desired measurement range.
- Available full-scale ranges:
20 Ω (high accuracy for low resistance measurements)
200 Ω (general-purpose resistance measurements)
2000 Ω (higher range for poor or dry soil conditions)

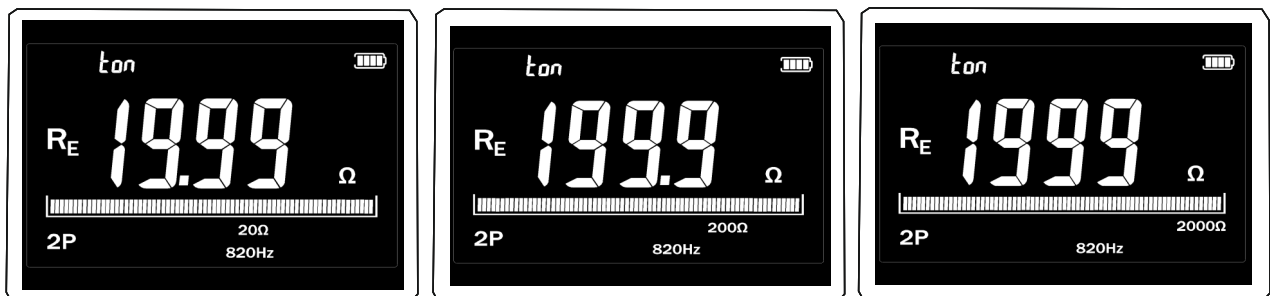

4.4 Test Frequency and Measurement Time

- The instrument uses internally generated test current with automatic 820 Hz frequency selection to reject electrical noise and ensure stable measurements.
- Typical measurement time is up to 10 seconds, depending on soil conditions and probe spacing.
- If readings are unstable, increase probe spacing or reposition the electrodes.

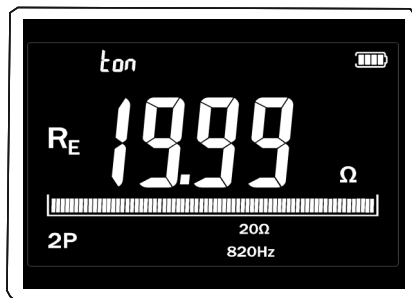

4.5 HOLD and Backlight Function

- Press HOLD / BL briefly to freeze the displayed reading; the HOLD symbol appears on the LCD..
- Press again to release the hold.
- The same key activates the LCD back-light for low-light conditions.
- The back-light automatically turns OFF after approximately 15 seconds to conserve battery power.

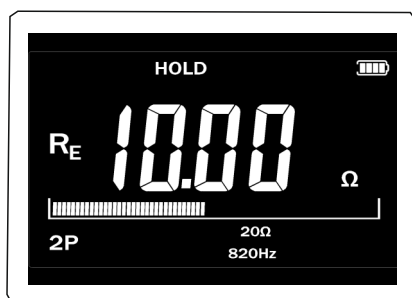

4.6 SAVE / LOAD Function (50 Readings Memory)

- Press SAVE after a measurement to store the reading; the memory index increments automatically.
- Press and hold LOAD to recall stored data.
- Use UP / DOWN keys to browse stored records.
- Press SAVE / LOAD again to exit recall mode.
- Stored readings are retained even after the instrument is powered OFF.

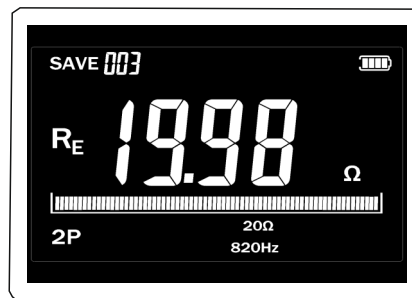

4.7 Display Back-light Operation

- Press HOLD / BL to activate the LCD backlight for viewing in low-light environments.
- The back-light automatically turns off after approximately 15 seconds to conserve battery power.

CHAPTER 5

SET-UP AND CONFIGURATION

This chapter explains site preparation, interference reduction, probe layout, and memory management to ensure accurate and reliable measurements.

5.1 Site Preparation and Soil Conditions

- Ensure clear soil access for auxiliary stakes (for 3P testing).
- Avoid buried metallic structures, pipes, or fences near the probes.
- For dry or rocky soil, lightly wet the area to improve electrical contact.
- Insert stakes firmly into the ground (minimum depth: 20-30 cm).
- Maintain recommended spacing between electrodes (refer to Chapter 6).

Note: Soil resistivity and moisture significantly affect measurement results. Multiple readings may be required for accuracy.

5.2 Interference & Noise Rejection Guidelines

To minimize electrical interference:

- Keep test leads away from power cables and transformers.
- Increase probe spacing if readings fluctuate.
- Avoid testing during lightning conditions or near energized grounding conductors.
- Start measurements using the highest resistance range.

Signs of interference include:

- Rapidly changing readings
- Intermittent "OL" indication
- Unstable bar-graph display

5.3 Memory Handling (Save, Recall, Clear)

- Up to 50 readings can be stored in memory.
- Stored data remains intact even after battery removal.
- To clear memory: press and hold the SAVE button for approximately 5 seconds in memory mode and confirm when prompted.

5.4 Recommended Test Lead Layouts

Proper lead placement ensures accurate measurement. Always install electrodes in a straight line and maintain appropriate distances.

3-Pole (3P) Layout

C ----- P ----- E

- Red Lead → C (Current probe)
- Yellow Lead → P (Potential probe)
- Green Lead → E (Earth electrode under test)

2-Pole (2P) Layout

E (Earth Electrode) ----- Reference Earth (P + C combined)

- Green Lead → E (Earth electrode)
- Red Lead → P + C (Reference earth)

General Guidelines

- Place the C (current probe) at the farthest distance possible from E.
- Place the P (potential probe) at approximately 20% to 50% of the distance between E and C.
- Keep all stakes aligned in a straight line to avoid ground loop influence.
- If results vary significantly when repositioning P, increase spacing and repeat the test.

Use the standard spacing ranges recommended in Chapter 6 for professional testing and result validation.

CHAPTER 6

MEASUREMENT PROCEDURES

This chapter provides step-by-step instructions for earth voltage and earth resistance measurements.

6.1 Earth Voltage Measurement

Purpose:

Measure AC potential difference between earth electrodes.

Connections:

- E → Earth electrode under test
- V → Reference ground

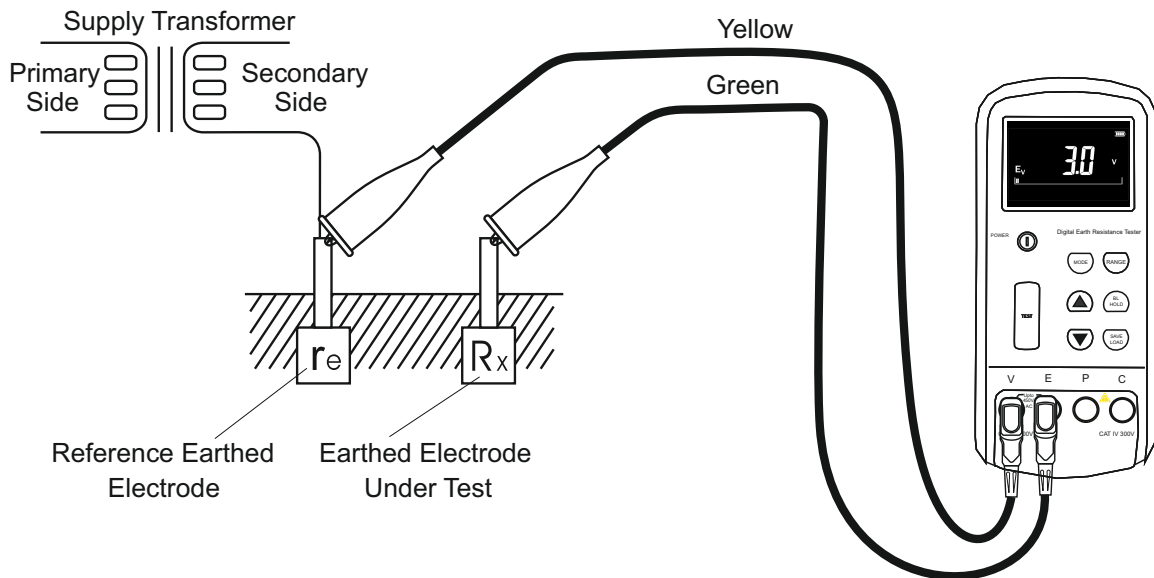

Warning: Do not connect to Line (L) or Line (L). Line (L) or Neutral (N).

Interpretation Guide

- 0 - 1 V → Normal → No action required
- 1 - 5 V → Acceptable → Monitor grounding condition periodically
- > 5 V → Abnormal → Investigate for leakage, neutral imbalance, or grounding issues
- > 25 V → Dangerous → Stop work immediately and inspect the grounding system

6.2 Two-Pole (2P) Earth Resistance Measurement

This method measures earth resistance using only two connections and is useful when installing stakes is impractical.

Connections:

- E → Earth electrode under test
- P+C → Secondary ground reference (pipe, neutral earth, or buried conductor)

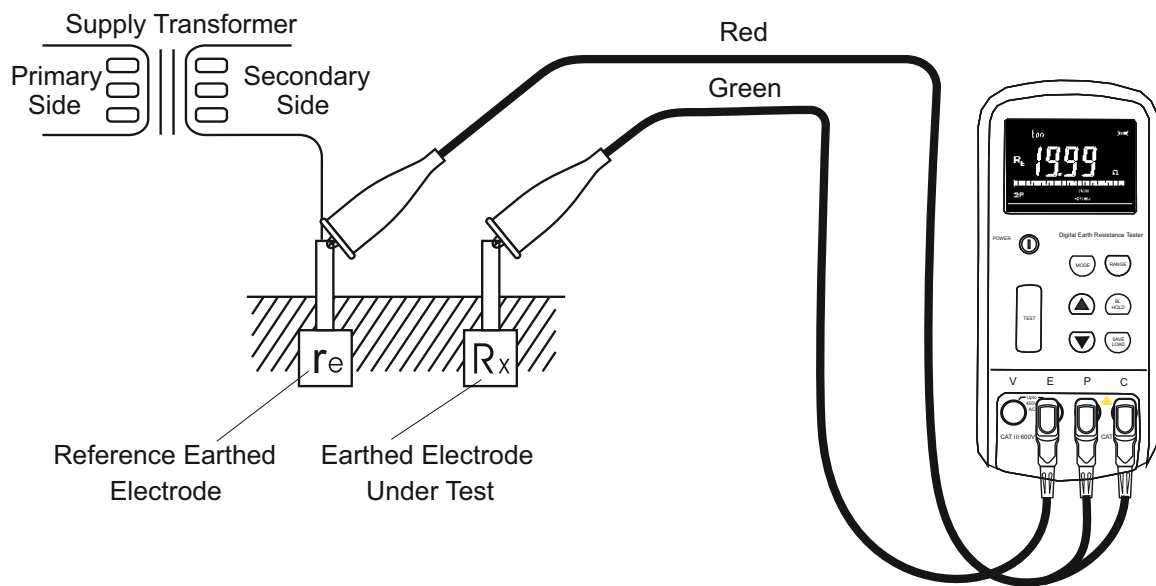

Procedure:

- Select 2P Mode using the MODE key.
- Connect the test leads to the terminals and reference ground.
- Press the TEST key to start measurement.
- Read the result displayed in Q (Ohms).

Note: The measured value includes the resistance of the reference ground. Use this method only when the reference ground is known to be low resistance, otherwise results may be inaccurate.

6.3 Three-Pole (3P) Earth Resistance Measurement

The 3P method provides more accurate and independent measurement using auxiliary probes.

Connections:

- E → Ground electrode under test
- P → Potential test probe
- C → Current test probe

Typical Spacing:

- E → P: 5-10 m
- P → C: 10-20 m

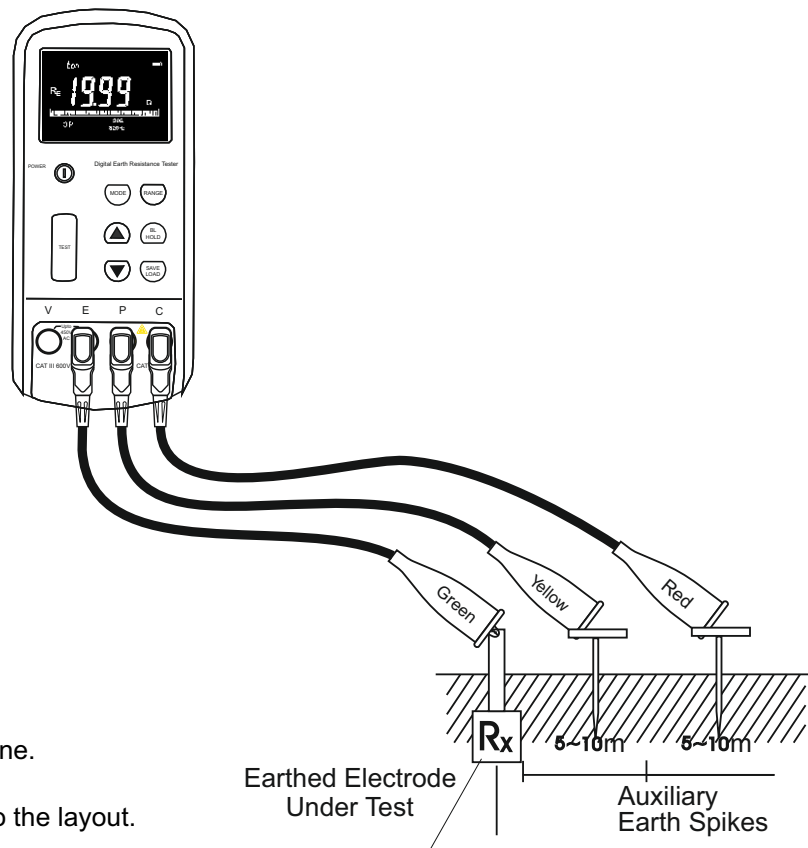

Procedure:

- Insert test stakes in a straight line.
- Connect test leads according to the layout.
- Select 3P Mode using the MODE key.
- Press the TEST key to start measurement.
- Wait for the reading to stabilize and note the value.

Tip: If readings fluctuate, increase stake distance or improve soil contact.

6.4 Using Existing Ground as Reference (Simple Method)

This method is used when installing test stakes is not possible (e.g., concrete or paved areas).

Steps:

- Connect the earth electrode under test to the E terminal.
- Connect the second lead from the P+C terminal to a verified low-resistance reference ground (such as a pipe or building earth).
- Select 2P Mode and press TEST.

Interpretation Guide

- 0 → 1 Ω → Excellent → Ideal for critical systems (transformers, substations)
- 1 - 5 Ω → Very good → Suitable for industrial grounding
- 5 - 10 Ω → Acceptable → Typical for residential distribution
- 10 - 25 Ω → Weak → Improve soil treatment or install additional electrodes
- > 25 Ω → Poor / Unsafe → Grounding system upgrade required

Note:

Acceptable values may vary depending on standards such as IS 3043, IEEE 142, and IEC 60364.

Additional Good Practices

- Perform multiple readings at different probe distances and ensure stability before finalizing results.
- Avoid measurements near buried metallic structures or power lines.
- If interference is suspected, increase electrode spacing or improve soil moisture.
- Compare results with site grounding design requirements and applicable standards

CHAPTER 7

CALIBRATION & PERFORMANCE

7.1 Measurement Principle (Ohm's Law – V/I)

- Earth resistance measurement is based on the fall-of-potential method.
- The instrument injects a known AC test current (I) into the earth system and measures the resulting voltage drop (V) across the electrode under test.
- Earth resistance is calculated using Ohm's Law:

$$R = V/I$$

- The use of AC test current minimizes the influence of stray DC voltages in the soil and improves measurement stability.

7.2 Earth Resistance Measurement-Accuracy & Performance

- Measurement Method: 2-Pole (2P) and 3-Pole (3P)
- Measurement Range: 20 Ω / 200 Ω / 2000 Ω

Resolution:

- 0.01 Q (20 Ω range)
- 0.1 Q (200 Ω range)
- 1 Q (2000 Ω range)

Accuracy :

- \pm (1.5% of reading + 10 digits) @ 20 Ω
- \pm (1.5% of reading + 5 digits) @ 200 Ω
- \pm (1.5% of reading + 5 digits) @ 2000 Ω

Test Current Injection: :

- 3.3 mAAC @ 20 Ω range
- 1.9 mAAC @ 200 Ω range
- 1.9 mAAC @ 2000 Ω range
- **Test Frequency:** 820 Hz
- **Open Circuit Voltage:** Maximum 47 V
- **Typical Measuring Time:** Up to 10 seconds
- **Interference Rejection:** 50 Vpp

7.3 Earth Voltage Accuracy & Reference Conditions

- Voltage Range: Up to 450 V AC
- Measurement Range: 20 Ω / 200 Ω / 2000 Ω

Resolution:

- 0.1 V (up to 199.9V)
- 1 V (up to 450 V)

Accuracy :

- \pm (1.5% of reading + 5 digits)

Reference Conditions:

- Pure sinusoidal AC waveform
- Ambient temperature: 23 °C \pm 5 °C

7.4 Reference & Environmental Conditions

Accuracy specifications are valid under the following conditions:

- Ambient temperature: 23 °C \pm 5 °C
- Relative humidity: < 85% RH (non-condensing)
- No external electromagnetic interference
- Correct test lead configuration (2P or 3P)
- Adequate electrode spacing during 3P measurements
- Temperature Coefficient: \pm 1% of applicable accuracy per 10°C

7.5 Open Circuit, Lead Error and Overload Indications

- Open-Circuit / Lead Error: Display shows “---” or unstable readings when the circuit is incomplete or connections are incorrect.

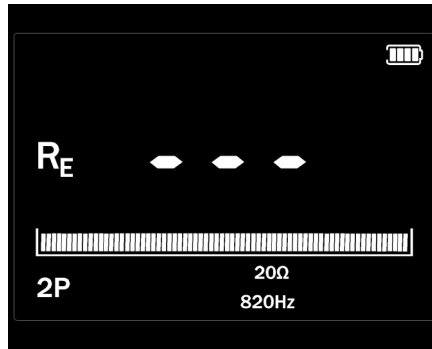

- Overload Indication: “OL” is displayed when the measured value exceeds the allowable range.

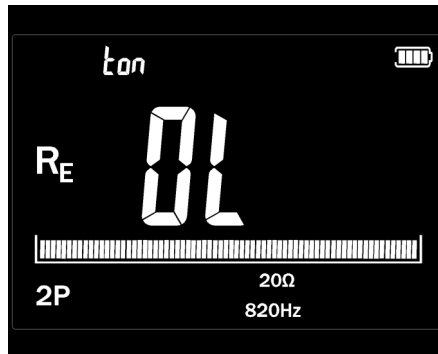

- The instrument automatically limits test current and protects internal circuitry during overload conditions.

CHAPTER 8

SPECIFICATIONS

Earth Resistance Measurement (2P / 3P)

Measurement Range	: 20 Ω, 200 Ω, 2000 Ω
Resolution	: 0.01 Ω (20 Ω), 0.1 Ω (200 Ω), 1 Ω (2000 Ω).
Test Current Injection	: 3.3 mA @20Ω range, 1.9 mA @200Ω range, 1.9 mA @2000Ω range.
Test Frequency	: 820Hz
Accuracy	: ±(1.5% of reading + 10 digits) @ 20Ω, ±(1.5 % of reading + 5 digits) @ 200Ω, @ 2000Ω.
Open Circuit Voltage	: Max. 47 V
Measuring time	: 10 seconds
Interference Rejection	: 50 Vpp
Overload Indication	: "OL" is displayed

Earth Voltage Measurement

AC Voltage Range	: Up to 450 V AC
Accuracy	: ±(1.5 % of reading + 5 digits)
Resolution	: 0.1 V (199.9 V), 1 V (450 V)
Measuring Frequency	: 50/60Hz
Overload Indication	: "OL" is displayed

Environmental Specifications

Operating Temperature	: -5 °C to +60 °C
Storage Temperature	: -30 °C to +70 °C (without Battery)
Relative Humidity	: Up to 85% RH (non-condensing)
Temp Coefficient	: ±1% of applicable accuracy per 10 °C

Power Supply

Battery	: 6 x AAA Standard Size
Battery type	: 1.5V Alkaline Batteries
Service Life	: Typically 10 sec * 1200 Operation

Mechanical Specification

Dimensions (W x H x D)	: 97 mm × 205 mm × 45 mm
Weight	: ~495 g (with batteries)
Enclosure Protection	: IP 40
Connector Protection	: IP 20
Case	: Rugged Portable Handheld Device

Display

Display Type	: 3½ Digit LCD with Back light
Main Character Height	: 17.53 mm
Sub-Character Height	: 6.61 mm
Display Count	: 1999 (as per Mode & range)

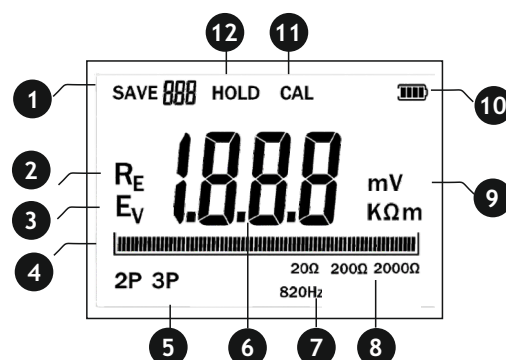

1. SAVE / LOAD Indication
2. Earth Resistance Indication (RE)
3. Earth Voltage Indication (EV)
4. Analog Bar Graph
5. Measurement Mode & Probe Method Selection
6. Measured Value Display
7. Test Signal Frequency
8. Selected Measurement Range
9. Measurement Units
10. Battery Status Indicator
11. Calibration Mode (CAL)
12. Display HOLD Indication

Safety & Compliance

Safety Standard	: IEC 61010-1
EMC Compliance	: IEC 61326-1
Performance Standards	: IEC 61557-1, IEC 61557-5
Pollution Degree	: 2
Measurement Rating	: CAT III 600 V CAT IV 300 V
Ingress Protection	: IP40 as per IEC 60529
CE Certification	: Yes

Note: The stated measurement accuracy is applicable when the instrument is used with the standard probes supplied by the manufacturer and under specified reference conditions.

CHAPTER 9

MAINTENANCE & SERVICE

9.1 General Maintenance & Cleaning

- Disconnect test leads before cleaning.
- Clean with a soft cloth and mild detergent.
- Avoid solvents, benzene, or abrasive materials.
- Inspect leads periodically for damage or wear.

9.2 Battery Replacement Procedure

- Ensure the instrument is switched OFF.
- Remove the battery compartment cover.
- Replace with new AAA alkaline batteries (6 pcs).
- Ensure correct polarity.
- Close the cover and power ON the instrument.

9.3 Storage & Transport

- Store in a dry, non-corrosive environment.
- Use the carrying case for transport.
- Remove batteries if stored for more than 3 months.
- Avoid impacts, vibration, and direct sunlight.

9.4 Service, Repair and Warranty

- Repairs must be performed by authorized service centers only.
- Tampering voids warranty.
- Standard warranty: 12 months (may vary).
- Annual calibration is recommended.

CHAPTER 10

ANNEXURES

10.1 Display Content Reference

- Q → Earth resistance mode
- Ev → Earth voltage mode
- C / P / E → Terminal indicators
- — → Lead open/error
- OL → Over Load -range
- Battery icon → Battery status

10.2 Quick Connection Guidelines

2-Pole (2P):

- Connect P and C together to the earth electrode
- Use short leads for quick checks

3-Pole (2P):

- C → Current probe
- P → Potential probe
- E → Earth electrode

Earth Voltage:

- Set instrument to voltage mode
- Connect across appropriate terminals
- No test current is injected

10.3 Quick Connection Guidelines

- Digital earth resistance tester
- Test leads (10 m, 10 m, 20 m)
- Auxiliary earth rods (2 pcs)
- Carrying case
- User manual
- AAA batteries (6 pcs)
- Manual QR

10.4 Glossary of Terms

- Earth Resistance: Resistance offered by soil and electrodes to fault current
- Fall-of-Potential Method: Standard method using spaced electrodes
- Test Current: AC current injected for measurement
- Touch Voltage: Voltage between conductive surfaces under fault
- Over-Range (OL): Measurement exceeds instrument capability

10.5 Revision History

- Version: Rev 1.0
- Description: Initial release

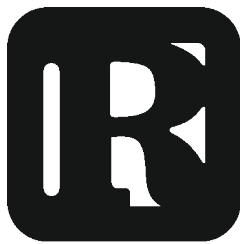

RISHABH

RISHABH INSTRUMENTS LIMITED

Factory: F-31, MIDC, Satpur, Nashik-422 007 India

Domestic (India): +91 253 2202028/99

International: +91 253 2202004/06/08/99

E-mail : International: global@rishabh.co.in

India: marketing@rishabh.co.in

Web: www.rishabh.co.in

Manual subject to change without notice.