



RISHABH

Multifunction Instrument

RISH LM 1360



Measure



Control



Record



Analyze



Optimize

RISH LM1360 measures important electrical parameters in 3 phase 4 wire, 3 phase 3 wire and 1 phase 2 wire Network. It displays many parameters at a glance. It measures electrical parameters like Active / Reactive / Apparent energy, power and all basic parameter. The instrument has two optional outputs. It can be configured as pulse output for energy measurement, limit output, timer function and RTC relay.

Applications:

- Internal Energy billing/monitoring/auditing
- Sub-metering
- Electrical load monitoring
- Genset, Test Benches and Laboratories

Product Features:

Energy as per IEC 62053:

- ▶ Rish LM1360 is available in Accuracy class 0.2s or 0.5s option.
- ▶ Active Energy accuracy 0.5s as per 62053-22 or optional 0.2s as per 62053-22
- ▶ Independent Import and Export Energy counter. Active energy (kWh), Reactive energy (kVArh), Apparent energy (kVAh) measurement.

THD and Individual Harmonics Measurement:

- ▶ The instrument measures per phase THD and individual harmonic up to 31st harmonics for voltage & current.

Limit (Alarm) or Pulse or RTC relay or Timer Relay Output (optional)

- ▶ Potential free, very fast acting relay contact. Configurable as pulse output which can be used to drive an external counter for energy measurement. Configurable as limit (alarm) switch.
- ▶ RTC relay can be used to control some instrument automatically over the period of a week repetitively.
- ▶ Timer output can be used to operate relay in cyclic manner.

USB Interface (Optional with datalogging):

- ▶ Isolated USB Interface for configuration of the Instrument, onsite access of measured parameter and downloading of logged data.

User Assignable Screens

- ▶ Instrument measures more than 85 parameters and these parameters are displayed through 28 different screens. For some applications user does not require all 28 screens, only few screens are required.
- ▶ So to have flexibility, Rishabh has added feature "User assignable screens". In which user can select minimum 1 no. and maximum 10 nos. of screens out of 28 screens as per application requirement.
- ▶ For example: If 5 screens are selected out of 28 screens, then display will scroll among that 5 selected screens.

RTC (Real Time Clock - Optional with datalogging):

- ▶ Inbuilt real time clock for display of date and time, along with time stamping for data logging and Event recording.

Data logging (Optional):

Meter has inbuilt 8MB Flash for datalogging.

- ▶ **Event Logging:** Previous 5 events of factory default parameters can be logged with Date and time.
- ▶ **Time based logging:** User selectable parameters (1 to 30) can be logged at regular intervals (1 to 60min) with Date and Time stamp in internal memory and can be accessed via Modbus or Ethernet or USB.
- ▶ If 1 Parameter for example energy is selected with logging interval of 15 minutes, log of maximum 948 days are available for user.
- ▶ If 30 Parameters are selected with logging interval of 60 minutes, log of maximum 355 days are available for user.
- ▶ **Load Profile logging:** Logging of energy consumed and peak Demand (Power and Current) in a day and in month for efficient tracking of load behaviors. Maximum 1 year daily and 14 years of monthly log is available for user.

Big LCD display with Back-lit :

- ▶ LCD shows 4 measurement parameters along with 9 digit energy parameter at a glance. It also shows load graphics and phase rotation symbol

Direct remote access (Optional):

- ▶ Remote configuration of the Instrument and access of measured parameter via Modbus or through Ethernet interface (Modbus TCP/IP).

Compliance to International Safety standards

- ▶ Compliance to International Safety standard IEC 61010-1- 2010

EMC Compatibility

- ▶ Compliance to International standard IEC 61326



Measure



Control



Record



Analyze



Optimize

Multifunction Instrument

RISH LM1360

Dimensions Details:

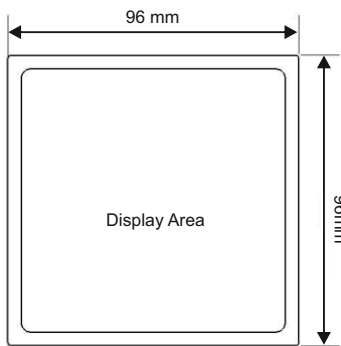

Front View

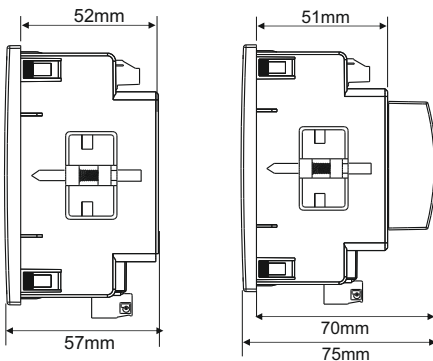

Side View

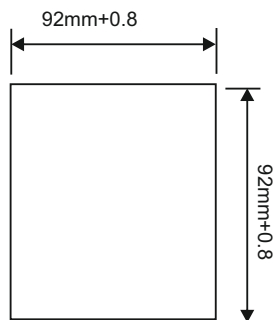

Panel Cutout

Technical Specifications:

Input Voltage:

Nominal input voltage (AC RMS) programmable on site.	100VLL to 600 VLL 57.5VLN to 346.42 VLN
System PT primary values	100VLL to 1200kVLL programmable on site.
Max continuous input voltage	120% of nominal value
Overload Withstand:	2 x rated value for 1 second, repeated 10 times at 10 second intervals
Overload Indication	"-OL-" >121% of Nominal value
Nominal input voltage burden	< 0.2VA approx. per phase at nominal 240V

Input Current:

Nominal input current	1A / 5A onsite programmable
System CT primary values	From 1A to 9999A
Max continuous input current	200% of nominal value
Overload Indication	"-OL-" >205% of Nominal value
Nominal input current burden	< 0.2VA approx. per phase
Overload Withstand:	20 x rated value for 1 second, repeated 5 times at 5 minute intervals

Auxiliary Supply:

Higher Auxiliary supply range	100-550V AC/DC (230V AC/DC nominal)
Lower Auxiliary supply range	12-60V AC/DC (24 V AC /48 V DC nominal)
Aux Supply frequency	45 to 65 Hz range
Auxiliary Supply burden (at nominal value)	
With Addon card	< 6VA approx.
With Ethernet card	< 8 VA approx.

Operating Measuring Ranges:

Current (Energy Measurement)	1...200% of nominal value
Starting current :	as per Standard IEC62053-22(0.5s) as per Standard IEC62053-22(Class 0.2s)(optional)
Voltage	20... 120% of nominal value
Power Factor	0.5 Lag ... 1... 0.8 Lead
Frequency	45Hz to 66Hz

Reference Conditions for Accuracy

Reference temperature	23°C +/- 2°C
Input Waveform	Sinusoidal(distortion factor 0.005)
Input frequency	50/60 Hz ± 2%
Auxiliary supply frequency	50/60 Hz ± 1%
Total Harmonic distortion	50% up to 15th Harmonics 10% up to 31st Harmonics (Current range 20%...100% of nominal value)
Voltage range	50%.....100% of nominal value
Current range	1%.....120% of nominal value

Accuracy

Active Energy	Class 0.5s as per IEC 62053 - 22 Class 0.2s as per IEC 62053-22(Optional)
Apparent Energy	Class 1
Reactive Energy	Class 2 as per IEC 62053 - 23



Measure



Control



Record



Analyze



Optimize

Electrical Connection:

Network Types :

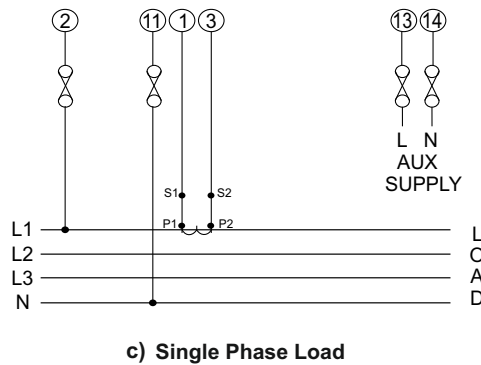
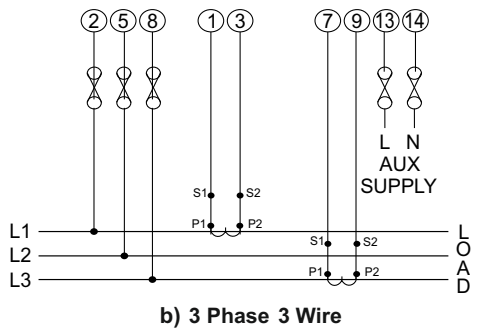
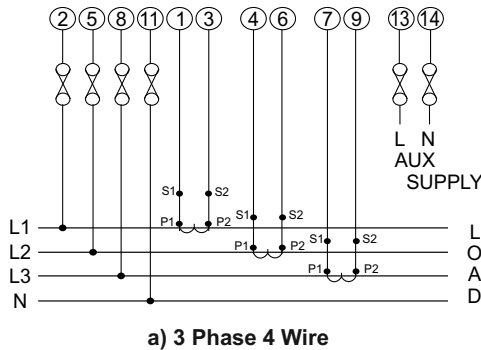

It is recommended that the wires used for connections to the instrument should have lugs soldered at the end. That is, the connections should be made with Lugged wires for secure connections.

Technical Specifications:

Accuracy

	Class 0.5s (Standard)	Class 0.2s (on request)
Voltage	± 0.5% of Nominal value	± 0.2% of Nominal value
Current	± 0.5% of Nominal value	± 0.2% of Nominal value
Frequency	± 0.2% of mid frequency	± 0.2% of mid frequency
Active Power	± 0.5% of Nominal value	± 0.2% of Nominal value
Re-Active Power	± 1.0% of Nominal value	± 1.0% of Nominal value
Apparent Power	± 0.5% of Nominal value	± 0.2% of Nominal value
Power Factor/ angle	±3°	±3°
THD (Voltage / Current)	±3%	±3%

Display update rate:

Response time to step input 1 sec approx.

Applicable Standards:

EMC	IEC 61326 - 1 : 2012, Table 2
Immunity	IEC 61000-4-3. 10V/m – Level 3 industrial Low level
Safety	IEC 61010-1-2010 , Permanently connected use
IP for water & dust	IEC60529
Pollution degree:	2
Installation category:	III

Isolation:

Protective Class	2
High voltage test	
Input+Aux Vs Surface	4kV RMS, 50Hz, 1min
Input Vs Remaining Circuit	3.3kV RMS, 50Hz, 1min

Environmental

Operating temperature	-20 to +70°C
Storage temperature	-25 to +75°C
Relative humidity	0... 95%RH (non condensing)
Warm up time	Minimum 3 minute
Shock (As per IEC60068-2-27)	Half sine wave, Peak acceleration 30gn (300 m/s ²), duration 18ms.
Vibration	10... 150...10 Hz, 0.15mm amplitude
Number of Sweep cycles	10 per axis
Enclosure	IP 20 (Terminal side) and IP54(Front side)

Interfaces

Impulse Led	For Energy testing
Relay(Optional)	250 VAC, 5 A AC 30VDC, 5A DC
Modbus (Optional)	RS485, max. 1200m Baud rate : 4.8k, 9.6k, 19.2k, 38.4k , 57.6kpbs.
Ethernet (Optional)	Ethernet access on Modbus TCP/IP Protocol.
BACnet (Optional)	BACnet IP with BACnet protocol version 12.



Measure



Control



Record



Analyze



Optimize

Memory calculations for Time based datalogging :

Max Memory Locations = 273030

Actual parameter stored in Each log = Date +time+Number of parameter selected by user

for ex. Number of parameter selected by user = 1.

Actual parameter stored in Each log = 1(Date) +1(time)+ 1 = 3

Maximum log that can be stored = Max Memory Location/Actual parameter stored in Each log
=273030/3= 91010

Timelog Interval setting = 15 minutes

Log in one day = (60 /Timelog Interval setting) * 24
=(60/15)*24 = 96

Max Days = Maximum log that can be stored / log in one day
= 91010/ 96 = 948.20 days

Measured Parameter System wise:

✓ : Available

× : Not Available

Sr No	Parameters	3 Phase 4Wire	3Phase 3Wire	1Phase 2Wire
1.	Import Active Energy ¹	✓	✓	✓
2.	Export Active Energy ¹	✓	✓	✓
3.	Inductive Reactive Energy ¹	✓	✓	✓
4.	Capacitive Reactive Energy ¹	✓	✓	✓
5.	Apparent Energy ¹	✓	✓	✓
6.	System Active Power (kW)	✓	✓	✓
7.	Active Power L1 (kW)	✓	×	×
8.	Active Power L2 (kW)	✓	×	×
9.	Active Power L3 (kW)	✓	×	×
10.	System Re-active Power (kVAr)	✓	✓	✓
11.	Re-active Power L1 (kVAr)	✓	×	×
12.	Re-active Power L2 (kVAr)	✓	×	×
13.	Re-active Power L3 (kVAr)	✓	×	×
14.	System Apparent Power (kVA)	✓	✓	✓
15.	Apparent Power L1 (kVA)	✓	×	×
16.	Apparent Power L2 (kVA)	✓	×	×
17.	Apparent Power L3 (kVA)	✓	×	×
18.	System Power Factor	✓	✓	✓
19.	Power Factor L1	✓	×	×
20.	Power Factor L2	✓	×	×
21.	Power Factor L3	✓	×	×
22.	System Phase Angle	✓	✓	✓
23.	Phase Angle L1	✓	×	×
24.	Phase Angle L2	✓	×	×
25.	Phase Angle L3	✓	×	×
26.	Current Demand	✓	✓	✓
27.	kVA Demand	✓	✓	✓
28.	Import kW Demand	✓	✓	✓
29.	Export kW Demand	✓	✓	✓
30.	Inductive Var Demand	✓	✓	✓
31.	Capacitive Var Demand	✓	✓	✓
32.	Max Current Demand	✓	✓	✓
33.	Max kVA Demand	✓	✓	✓
34.	Max Import kW Demand	✓	✓	✓
35.	Max Export kW Demand	✓	✓	✓



Measure



Control



Record



Analyze



Optimize

Multifunction Instrument

RISH LM1360

Measured Parameter System wise:

✓ : Available

✗ : Not Available

Sr No	Parameters	3 Phase 4Wire	3Phase 3Wire	1Phase 2Wire
36.	Max Inductive Var Demand	✓	✓	✓
37.	Max Capacitive Var Demand	✓	✓	✓
38.	Run Hour	✓	✓	✓
39.	On Hour	✓	✓	✓
40.	Number of Interruptions	✓	✓	✓
41.	System Voltage	✓	✓	✓
42.	Voltage L1	✓	✗	✗
43.	Voltage L2	✓	✗	✗
44.	Voltage L3	✓	✗	✗
45.	Voltage L12	✓	✓	✗
46.	Voltage L23	✓	✓	✗
47.	Voltage L31	✓	✓	✗
48.	System Voltage THD	✓	✓	✓
49.	Voltage L1 THD	✓	✓	✗
50.	Voltage L2 THD	✓	✓	✗
51.	Voltage L3 THD	✓	✓	✗
52.	System Current	✓	✓	✓
53.	Current L1	✓	✓	✗
54.	Current L2	✓	✓	✗
55.	Current L3	✓	✓	✗
56.	System Current THD	✓	✓	✓
57.	Current L1 THD	✓	✓	✗
58.	Current L2 THD	✓	✗	✗
59.	Current L3 THD	✓	✓	✗
60.	Individual Harmonics of VL1(Up to 31st Harmonics)	✓	✓	✓
61.	Individual Harmonics of VL2 (Up to 31st Harmonics)	✓	✓	✗
62.	Individual Harmonics VL3 (Up to 31st Harmonics)	✓	✓	✗
63.	Individual Harmonics IL1(Up to 31st Harmonics)	✓	✓	✓
64.	Individual Harmonics IL2(Up to 31st Harmonic)	✓	✗	✗
65.	Individual Harmonics IL3(Up to 31st Harmonics	✓	✓	✗
66.	Neutral Current	✓	✗	✗
67.	Frequency	✓	✓	✓
68.	RPM	✓	✓	✓
69.	Phase Reversal Indication	✓	✗	✗
70.	Current Reversal Indication	✓	✗	✓
71.	Phase Absent Indication	✓	✗	✗
72.	Old Import Active Energy ²	✓	✓	✓
73.	Old Export Active Energy ²	✓	✓	✓
74.	Old Inductive Reactive Energy ²	✓	✓	✓
75.	Old Capacitive Reactive Energy ²	✓	✓	✓
76.	Old Apparent Energy ²	✓	✓	✓
77.	Old Run Hour ²	✓	✓	✓
78.	Old On Hour ²	✓	✓	✓
79.	Old Number of Interruptions ²	✓	✓	✓
80.	Old Max kW Import Demand ²	✓	✓	✓
81.	Old Max kW Export Demand ²	✓	✓	✓
82.	Old Max Var Inductive Demand ²	✓	✓	✓
83.	Old Max Var Capacitive Demand ²	✓	✓	✓
84.	Old Max VA Demand ²	✓	✓	✓
85.	Old Max A Demand ²	✓	✓	✓

Note: 1. Energy on display is autoranging & unit for Energy parameters on modbus are dependent on CT PT ratio or unit selected by user.
2. Parameters are available only on modbus.



Measure



Control



Record



Analyze



Optimize

Order Code:

Ordering Information:

Product Code : MA4L - 4 - 3 - 01 - 02 - X - X - X - 0000

R : RS485 - 2 Pulse Output
E : Ethernet
D : Ethernet - Datalogging
U : RS485 - 2 Pulse Output - Datalogging - USB
G : GSM
B : BACnet IP
Z : NONE

H : 100 - 550 V AC/ DC
L : 12 - 60 V AC/ DC

2 : Accuracy class 0.2s
5 : Accuracy class 0.5s

Order Code Example:

MA4L-430102RH20000

LM1360 3Phase input with input voltage 100-600VLL with 1A/5A internal CT , auxiliary voltage 100 to 550 V AC DC ,with MODBUS (RS485),with 2 pulse output with accuracy class 0.2s.



Measure



Control



Record



Analyze



Optimize



RISHABH



Measure



Control



Record



Analyze



Optimize

RISHABH INSTRUMENTS LIMITED

Domestic (India): +91 253 2202099 | marketing@rishabh.co.in
International: +91 253 2202004/06/08/99 | global@rishabh.co.in
www.rishabh.co.in