



Power Factor Controller

RISH PFC 08



Measure



Control



Record



Analyze



Optimize

Application :

RISH PFC 08 is power factor controller for reactive power compensation. it controls external reactive power element (Capacitor) to meet reactive power demand of the load. This reduces burden on source to supply additional reactive current. precise and fast measurements are useful tool for system analysis. powerful protection function protects system and switching element in case of system faults

Product Features:

Autoinitialisation Function:

Controller has auto init function to detect

1. Number of capacitors connected (Capacitor bank count)
2. Capacitor kvar value
3. Phase correction angle

Capacitor programming option:

Each output capacitor kvar can be programmed either as

1. Direct kvar value
2. Control series
3. Auto detected value

Control Output:

Controller is available in basic 4 , 6 , 8 output option Selectively each output capacitor can be configured as permanently ON (Fixed compensation) , Permanently Off (Faulty Bank) , Auto mode.

Control Scheme:

Controller has intelligent control of outputs so that equal use of system resources is ensured additionally capacitor health monitoring option is available to detect loss of capacitor power for preventive action.

Manual Mode:

Controller has manual function for bank connection / disconnection that is used for diagnosis purpose.

Test Run Function:

To measure kVAr value of connected capacitor bank test run function is used. banks are connected and disconnected sequentially and effective change in PF monitored so to calculate capacitor bank value

Programmable PFC parameters:

Target PF, Number of banks , Bank kVAr value , connecting time , disconnecting time , discharge time , maximum switching kVAr , switching threshold etc.

Programmable system configuration

Voltage and current inputs are configurable and system adopt itself according to configuration so that correct functioning is possible

Voltage Input is configurable as VLN or VLL (R / Y / B)

Current Input is configurable as IR(kl),IY(kl),IB(kl) or IR(lk),IY(lk),IB(lk)

Protections and Alarm

Alarm relay can be activated for one or more following events
High voltage , Low voltage , undercurrent , over-current, over-temperature, Frequency faults , over harmonics-voltage , over harmonics current, out of bank (under compensation) , overcompensation

For each of above event except under and overcompensation capacitors are switched off sequentially to protect capacitor banks



Controller generates system warning for

1. Over temperature ,
2. If output switching count limit sets exceeds set value
3. Battery low (if RTC used)
4. Capacitor health fault

Programmable energy meter parameters

CT ratio , Nominal voltage , Energy unit for ex (Wh , kWh , Mwh) , energy display resolution (7 / 8 / 9) digits , energy updation rate on modbus (1-60 min) , Demand integration time.

Programmable Display parameter

Display contrast level , auto scrolling (On/Off) , backlit (On/Off) are configurable for any viewing condition

System parameter Min / Max value storage:

Minimum / maximum values of voltage , current , Frequency , Temperature, Maximum values of kW , V-thd , I-thd are logged

Demand parameters

Demand for kW , kVAr , kVA (import / Export) are logged

THD and individual harmonics

Individual harmonics upto 31st and THD for voltage and current are continuously calculated and displayed

Energy measurement (Import and Export):

Active , Reactive , Apparent energy is measured

High contrast 16 x 2 LCD display:

Adjustable contrast with backlit on / off function

Reset Function :

Instrument has reset function which used to Reset

1. Minimum , maximum value of parameters recorded.
2. Switching count , operation time of each bank or all at once
3. Energy counter
4. Demand
5. ON / RUN hour
6. Interruption count

Optional MODBUS (RS485) Output

The optional ModBus output enables the instrument to transmit all the measured parameters over standard MODBUS (Rs485).

Enclosure Protection for dust and water:

conforms to IP 54 (front face) as per IEC60529

Compliance to International Safety standards

Compliance to International Safety standard IEC 61010-1- 2001

EMC Compatibility

Compliance to International standard IEC 61326



Measure



Control



Record



Analyze



Optimize

Technical Specifications:

Accuracy:

Voltage	± 0.5% of Nominal value
Current	± 0.5% of Nominal value
Frequency	± 0.15% of mid frequency
Active Power	± 1.0 % of Nominal value
Re-Active Power	± 1.0 % of Nominal value
Apparent Power	± 1.0 % of Nominal value
Active energy (kWh)	± 1.0 % of Nominal value
Re Active energy (kVArh)	± 1.0 % of Nominal value
Apparent energy (kVAh)	± 1.0 % of Nominal value
Total Harmonic Distortion	± 1.0 % of Applied value

Measurement error is normally much less than the error specified above. Variation due to influence quantity is less than twice the error allowed for reference condition

Influence of Variations:

Temperature coefficient :(for rated value Range of use (0...50°C))	0.05%/°C for Voltage (50... 120% of rated value) and 0.05%/°C for Current (10... 120% of rated value)
---	--

Display update rate:

Response time to step input	1 sec approx.
-----------------------------	---------------

Applicable Standards:

EMC	IEC 61326-1:2012, Table 2
Accuracy	IEC 62053-21
Safety	IEC 61010-1-2010
IP for water & dust	IEC60529
Pollution degree:	2
Installation category:	III
High Voltage Test	2.2 kV AC, 50Hz for 1 minute between all electrical circuits

Environmental

Operating temperature	-10 to +60°C
Storage temperature	-20 to +65°C
Relative humidity	0... 90% non condensing
Warm up time	Minimum 3 minute
Shock	15g in 3 planes
Vibration	10... 55 Hz, 0.15mm amplitude

Fault / Event	Limits	Default Trip values	Restore values
Under-voltage	75 - 90 % of Vnom	85 %	3% + trip value
Over-voltage	105 -115 % of Vnom	115 %	2% - trip value
Under-Frequency	2 -10 % of Freq-Nom	6 %	1 % of Freq-Nom
Over-Frequency	2 -10 % of Freq-Nom	6 %	1 % of Freq-Nom
Under-current	1 - 3 % of CT primary	2 %	1% of CT primary + trip value
Over-current	60 -120 % of CT primary	110 %	1% of CT primary - trip value
V-thd	1 - 25 %	7 %	2%
I-thd	1 - 99 %	7 %	2%
Temperature	---	60 Degree celcius	55 Degree celcius
Overcompensation / Out of bank	Threshold x Min CkVAR	Threshold x Min CkVAR	Demand kVAR > Min CkVAR



Measure



Control



Record



Analyze



Optimize

Technical Specifications:

Number of outputs:	Upto 8 Max
Alarm output:	1
Target PF range:	0.8 Ld to 0.8 Lg
Switching Threshold:	30 to 100 %
Switch-in-time (Connecting Time):	10 to 1800 Sec
Switch-off-time (Disconnecting Time):	10 to 1800 Sec
Discharge time:	60 to 1800 Sec
Input Voltage:	
Nominal input voltage (AC RMS)	240 V
Input Current:	
Nominal input current	1A / 5A AC RMS.
System CT secondary values	1A & 5A programmable
System CT primary values	From 1A up to 9999A
Max continuous input current	120% of rated value
Supply (Auxiliary) Voltage:	
AC supply voltage range	110 V AC to 550 VAC
AC supply frequency range	40 to 70 Hz
VA Burden:	
Nominal input voltage burden	< 0.2 VA approx. per phase
Nominal input current burden	< 0.6 VA approx. per phase
Auxiliary Supply burden	< 10 VA approx
Overload Withstand:	
Voltage	2 x rated value for 1 second, repeated 10 times at 10 second intervals
Current	20 x for 1 second, repeated 5 times at 5 min
Operating Measuring Ranges:	
Voltage	30 - 550 VAC
Current	3 mA measuring starting current , 10 mA operating current , Max 6 Amp
Frequency	40...70 Hz
Reference conditions for Accuracy:	
Reference temperature	23°C +/- 2°C
Input waveform	Sinusoidal (distortion factor 0.005)
Input frequency	50 or 60 Hz ±2%
Auxiliary supply voltage	Rated Value ±1%
Auxiliary supply frequency	Rated Value ±1%
Voltage Range	50... 100% of Nominal Value. 60... 100% of Nominal Value for THD.
Current Range	10... 100% of Nominal Value. 20... 100% of Nominal Value for THD.
Power	Cos phi / sin phi = 1 for Active / Reactive Power & Energy. 10... 100% of Nominal Current & 50... 100% of Nominal Voltage.



Measure



Control



Record



Analyze



Optimize

Connection Diagram:

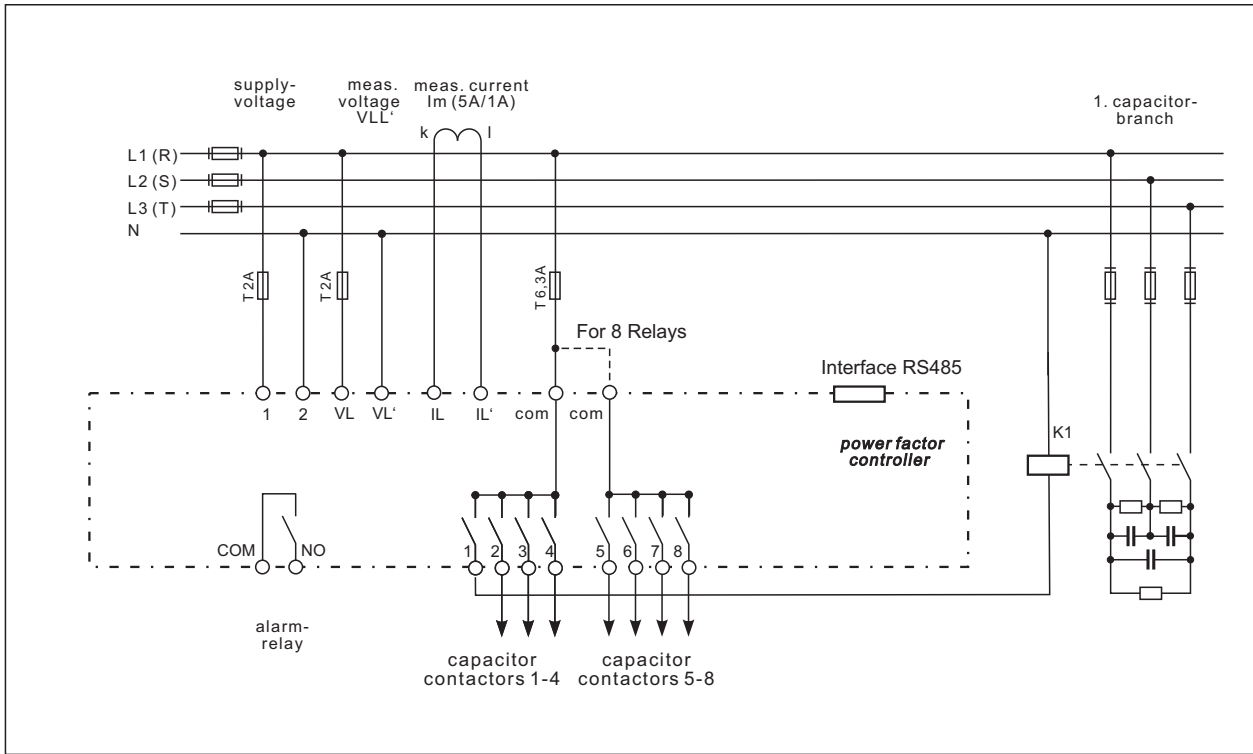

Dimensions:

Without add on card
 96 x 96 x 59 mm

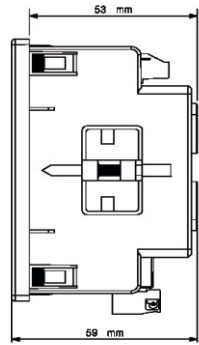
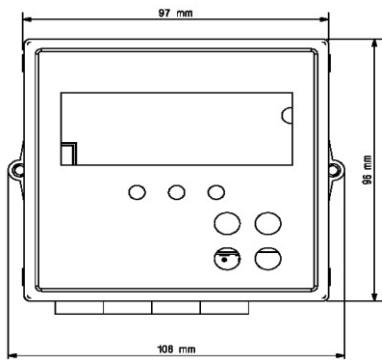

With add on card
 96 x 96 x 75 mm

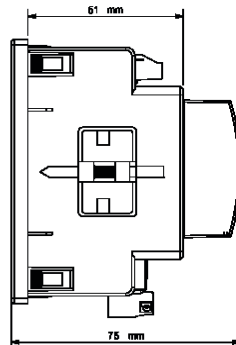
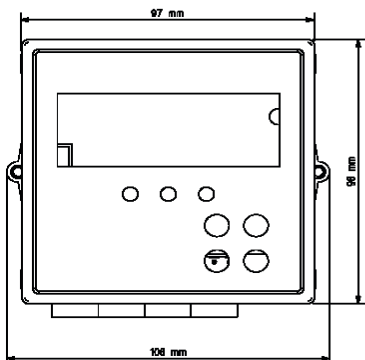

Measure



Control



Record



Analyze



Optimize

Parameter Measurement and Display:

Sr No	Displayed Parameters	Sr No	Displayed Parameters
1.	Voltage	24.	Min , Max Voltage
2.	Current	25.	Min , Max Current
3.	Power factor , Bank status	26.	Min , Max Frequency
4.	Active Power	27.	Min , Max Temperature
5.	Re-active Power (kVAR)	28.	Max VTHD
6.	Apparent Power	29.	Max ITHD
7.	Difference kVAR to Target Power factor	30.	Max active import power
8.	Frequency	31.	Max active export power
9.	THD-V , THD-I in %	32.	Max reactive capacitive power
10.	Individual harmonics upto 31st	33.	Max reactive inductive power
11.	Energy kWh (Import , Export)	34.	Max Apparent power
12.	Energy kVARh (Inductive , Capacitive)	35.	Max active import demand
13.	Energy kVAh	36.	Max active export demand
14.	Demand kVA	37.	Bank switching count (Number of banks configured)
15.	Demand current	38.	Bank operation time (Number of banks configured)
16.	Run Hour	39.	Bank value (Number of banks configured)
17.	On Hour	40.	Test run menu
18.	Number of interruptions		
19.	System fault window1		
20.	System fault window2		
21.	Date / Time		
22.	System warning		
23.	Active demand Import, Export		

Order Code :

Model	RISH PFC 08
Relay stages	4
	6
	8
MODBUS (OPTIONAL)	
MODBUS (Rs485 Output)	R
MODBUS Option not used	Z
RTC (OPTIONAL)	
RTC	RTC
RTC Option not used	Z

Order Code Example:

RISH PFC 08-8-R-RTC

RISH PFC 08 with 8 relay modbus and RTC



Measure



Control



Record



Analyze



Optimize



RISHABH



Measure



Control



Record



Analyze



Optimize

RISHABH INSTRUMENTS LIMITED

Domestic (India): +91 253 2202099 | marketing@rishabh.co.in
International: +91 253 2202004/06/08/99 | global@rishabh.co.in
www.rishabh.co.in