

RISHabh *Lab*

The Protector Trip Relay Series

Data Sheet

D.C. Voltage Rrelay

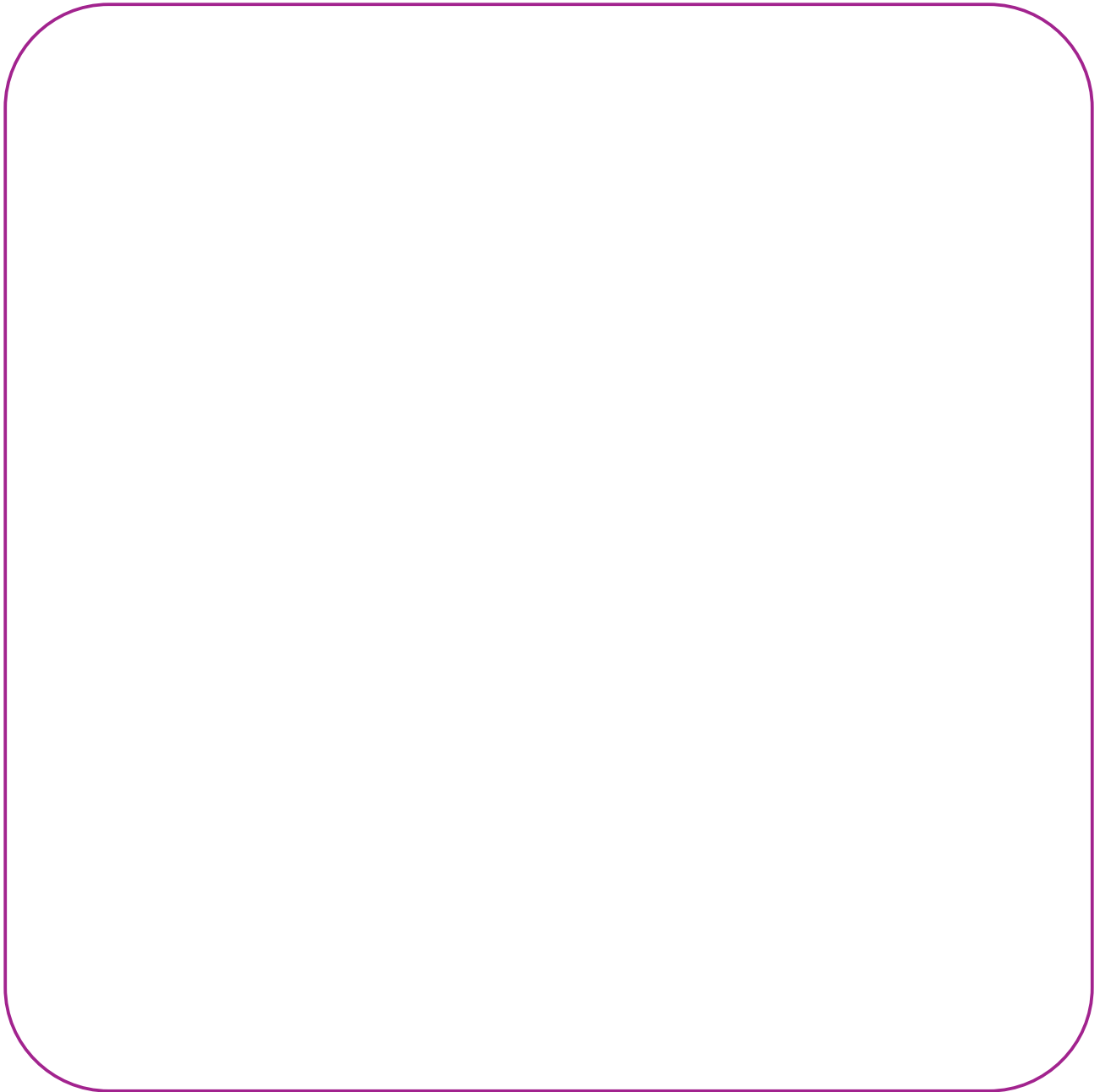

Measure



Control



Record





Analyze



Optimize

Models available

	
Function / System	Product Type
Earth Fault Relay 5 A 230V AC Aux	253 - EFR

Features

- Detection of Earth leakage
- Adjustable Earth Fault Percentage
- Adjustable Time Delay
- Testing Simulation
- Manual & Remote reset
- LED indication for Trip & Power ON
- 2 pole relay contacts
- Polycarbonate casing (UL 94 V-0)
- Protective clear terminal cover (UL 94 V-0)

Applicable Standards

Applicable Standard	: BS 60255, IS 3231-1997
Safety Requirements	: BS 5458, IEC 414
Temperature Range	: 0° C to 60° C
Storage Temperature	: 20° C to 70° C
Temp. Co-efficient	: 0.05% per °C
Enclosure Code	: IP50 to BS5490, IEC 259

Trip Setting :-

Delayed Tripping - If no link is present between terminal 5 & 6, EFR will trip as per the time selected on front panel.

LED indicates the trip condition and relay trips after crossing the set point.

Instantaneous Tripping - If link is present between terminals 5 & 6 EFR will trip instantaneously on occurrence of earth fault condition. (Time delay is bypassed)

Test & Reset: - Relay can be tested without connecting it in the control circuit. Connect the required aux input (Indication LED L1 should become ON), check the O/P relay contacts at 13 and 15. Press TEST button. Now RESET the relay either by pressing RESET the relay either by pressing RESET button or shorting pin no 10 & 11, the relay will be de-energized. If these operations are satisfactory, relay is working properly and can be used with load.

Specifications

Auxiliary Supply	: 230 V AC \pm 20%
Frequency of Aux. Supply	: 50Hz \pm 3%

Rated Current Input :

5A/1A (Selection via Terminals)	
Terminals 1 & 2	:Current Input 5A
Terminals 1 & 3	:Current Input 1A

Frequency of Current Input	: 50 Hz \pm 3%
----------------------------	------------------

Power Consumption : 4.5 VA max.

Output Relay Contact : 2 CO

Output Contact Rating :

A.C.	: 5A, 240 VAC (Resistive)
D.C.	: 24V 5A resistive

Life Expectancy : 0.5 x 10⁶ operations at 100% rating

EF Trip Setting : 10% to 90% of rated Current Input (Variable)

Set Accuracy : \pm 5% w.r.t. Current input of 100% (Full Scale)

Trip Time delay : 1 -10 Sec. \pm 10% (Adjustable) Instantaneous (Link Selectable)

Reset : Manual / Remote Reset

Indication : ON (Green) - Power ON
EF (Red) - TRIP

Current Sensor : Neutral CT CBCT/
Summation CT secondary current
Rating of 1A or 5A (Protection Class)

Operating condition :

Temperature	: 0 °C to 60 °C
Humidity	: Upto 95% R.H.
Enclosure	: Polycarbonate (UL 94 V-0)

Dimensions (mm)	:
Overall	75 x 70 x 112
Mounting	35 x 55

Weight : 400 gms. approx.

Product function

The relay is provided with settable EFR, current trip settings & settable trip time delay. Relay energises on fault condition. External CTs to be installed along with EFR, of secondary rating of 5 A or 1 A, can be selected via terminal 1 & 2 or 1 & 3 respectively.

When the Aux power is applied to the EFR inside relay remains in de-energised condition. When input current exceeds Earth Fault set level the relay energises after set trip time delay. (Refer Note).

The EFR operates in manual reset mode. For resetting it is necessary to press RESET push button provided on front panel of EFR. Relay can also be resetted by using external NO type remote reset push button (if connected externally at terminals 10 & 11)

Note :

EFR does not operate in fail safe operation mode. EFR is available in "Relay Energizing on fault " condition logic (i.g. Revers Logic). Before installing EFR ensure that the system & wiring connection are proper & temper proof.

Electrical Connections

NOTE : RELAY CONTACT SHOWN FOR UNIT IN HEALTHY CONDITION

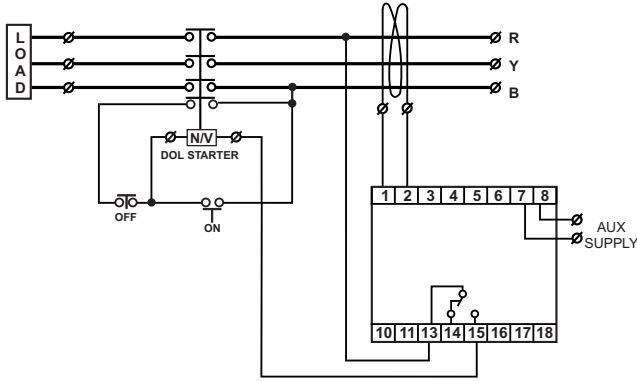

NOTE : RELAY CONTACT SHOWN IN TRIP CONDITION.
CT CONNECTIONS SHOWN FOR CBCT WITH 5 Amp. SEC RATING.

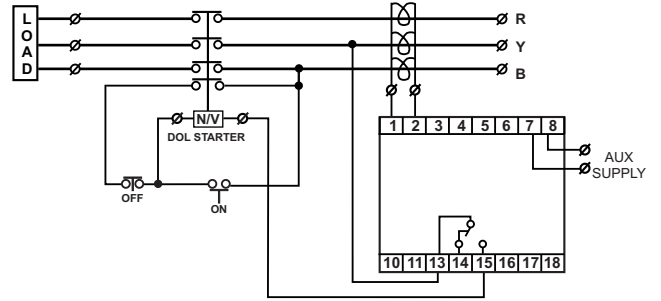

NOTE : RELAY CONTACT SHOWN IN TRIP CONDITION.
CT CONNECTIONS SHOWN FOR INDIVIDUAL 5 Amp. SEC CT USED IN EACH PHASE.

Connection diagram

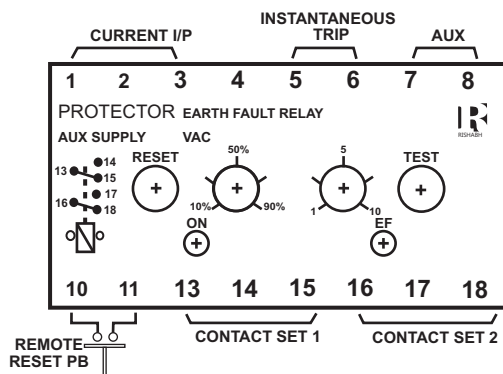

Dimensions

Model 253

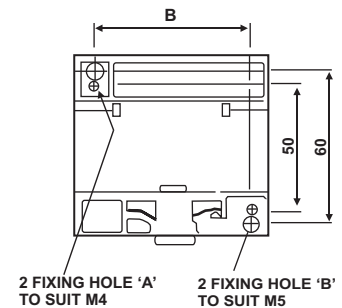
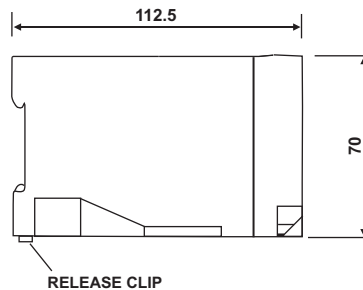
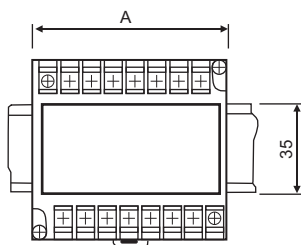

Model	A	B
253	75	60

Ordering Information

Please quote :

1. Product Type.
2. Function i.e. Under or Over.
3. Relays normally de - energise on under trip and energise on over trip.
4. Please specify standard or non standard trip. An energised relay is indicated by a "Lit" red LED. Setpoint can be factory adjusted to your requirements.
5. System Voltage and/or Current where applicable.
6. System Frequency.
7. Auxiliary Voltage where required.
8. Preset Differential where required.
9. Time delay where applicable.



Measure



Control



Record



Analyze



Optimize

RISHABH INSTRUMENTS LIMITED

Domestic (India): +91 253 2202099 | marketing@rishabh.co.in
International: +91 253 2202004/06/08/99 | global@rishabh.co.in
www.rishabh.co.in