

LOW VOLTAGE CURRENT TRANSFORMER

RISHABH *Xmer* SERIES



Data Sheet

SQUARE TYPE CURRENT TRANSFORMER



Measure



Control



Record



Analyze



Optimize

LOW VOLTAGE CURRENT TRANSFORMER

Applicable standard: - IEC-61869-1&2 / IEC- 60044 -1, BS 3938, IS 2705 -1,2&3.

Case: - Unfilled polycarbonate, flame retardant grades classified UL 94V-0.

Connection: - Two connection on each side. M4 screws with self lifting clamp strap assembly for RishXmer series and 1 connection on each side M4 screws with self lifting clamp strap for Rish CT series.

Insulation class: - E (120°C max)

System voltage: - 720V maximum

Test voltage: - For Ring (Window) type CT : 4KV 50 Hz for 1 min (except for 50/30 CT type and 50/50 CT type where test voltage is 3KV 50 Hz for 1 min)
For Wound type CT : 3KV 50 Hz for 1 min

Operating frequency: - 50Hz / 60 Hz

Rated primary rating: - 1A to 7500A

Rated secondary output: - 5A standard (1A on request)

Rated burden: - 1, 1.25, 1.5, 2.5, 3.75, 5, 7.5, 10, 12.5, 15, 20, 30, 45, 60, 100 VA

Class of accuracy: - 0.2, 0.2S for laboratory and power measurement
0.5, 0.5S for accurate measuring, kWh
1 for general measurement
3 for indicating instruments

Ambient temperature: - -25°C to +40°C

Storage temperature: - -50°C...+80°C

Thermal short circuit current (I_{th}):- 40xI_n for Wound type CT and 60xI_n for Bus Bar type CT.

Dynamic short circuit current (I_{dyn}):- 2.5xI_{th}

Instrument security factor (FS): - 2.5, 5, 10

Features

Wide range of system current Ratings.

Hinged terminal cover.

Various mounting options like DIN rail mounting, Wall mounting.

Terminal with self lifting screw with dual connection facility giving access from both sides of transformers.



Measure



Control



Record



Analyze



Optimize

RISH XMER WOUND PRIMARY SERIES

RISH χ mer 62W (40)

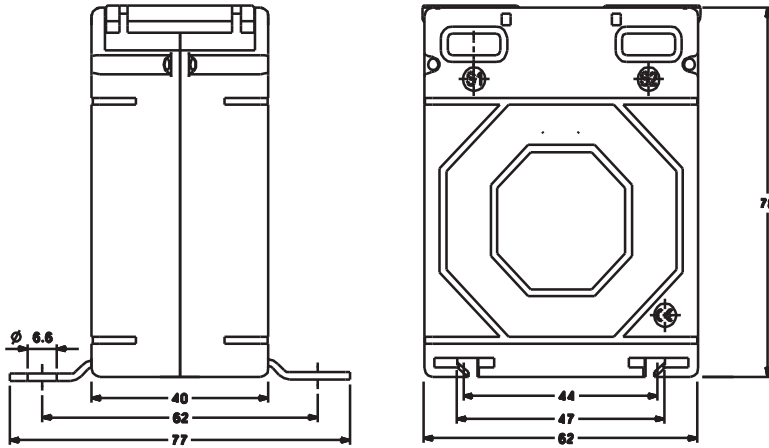

Primary Current	RISH χ mer 62W (40)		
	Accuracy		
	0.2	0.5	1.0
1A	1VA	2.5VA	5VA
2.5A	1VA	2.5VA	5VA
5A	1VA	2.5VA	5VA
7.5A	1VA	2.5VA	5VA
10A	1VA	2.5VA	5VA
15A	1VA	2.5VA	5VA
20A	1VA	2.5VA	5VA
25A	1VA	2.5VA	5VA
30A	1VA	2.5VA	5VA

Without Aperture

RISH χ mer 74W (45)

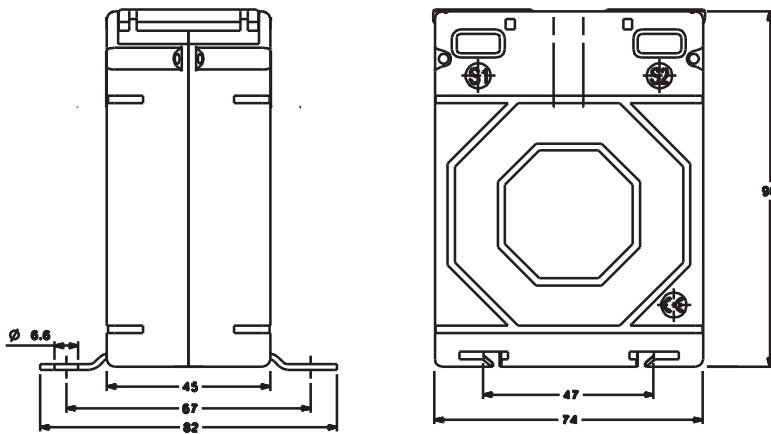

Primary Current	RISH χ mer 74W (45)		
	Accuracy		
	0.2	0.5	1.0
1A	1.5VA	5VA	10VA
2.5A	1.5VA	5VA	10VA
5A	1.5VA	5VA	10VA
7.5A	1.5VA	5VA	10VA
10A	1.5VA	5VA	10VA
15A	1.5VA	5VA	10VA
20A	1.5VA	5VA	10VA
25A	1.5VA	5VA	10VA
30A	1.5VA	5VA	10VA
40A	1.5VA	5VA	10VA
50A	1.5VA	5VA	10VA
60A	1.5VA	5VA	10VA

Without Aperture

RISH χ mer 45 SERIES

RISH χ mer 45/14(40)

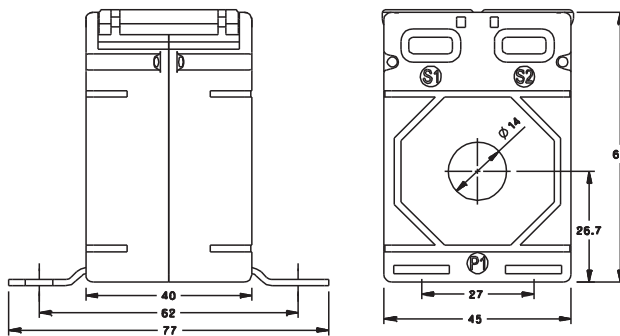

Primary Current	RISH χ mer 45/14(40)	
	Accuracy	
	0.5	1.0
30A	-	1VA
40A	-	1VA
50A	-	1.5VA
60A	-	1.5VA
75A	1.5VA	2.5VA
80A	1.5VA	2.5VA
100A	1.5VA	3.75VA
120A	2.5VA	3.75VA
125A	2.5VA	3.75VA
150A	2.5VA	5VA
200A	3.75VA	7.5VA
250A	5VA	7.5VA
300A	5VA	10VA

RISH χ mer 45/21(40)

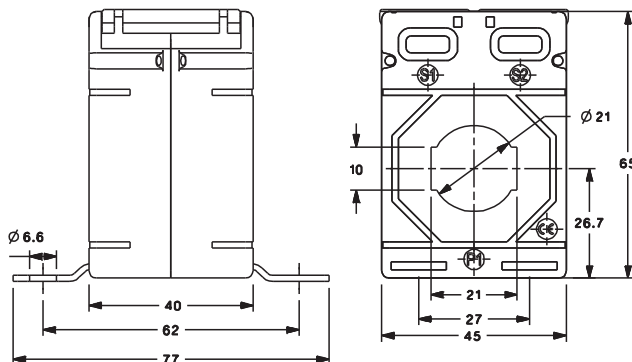

Primary Current	RISH χ mer 45/21(40)	
	Accuracy	
	0.5	1.0
50A	-	1.5VA
60A	-	1.5VA
75A	-	2.5VA
80A	1VA	2.5VA
100A	1.5VA	3.75VA
120A	1.5VA	3.75VA
125A	2.5VA	3.75VA
150A	2.5VA	5VA
200A	3.75VA	5VA
250A	5VA	5VA
300A	5VA	5VA
400A	5VA	5VA

RISH χ mer 50/14 (30), 50/21 (30) and 50/30 (30) SERIES

RISH χ mer 50/14 (30)

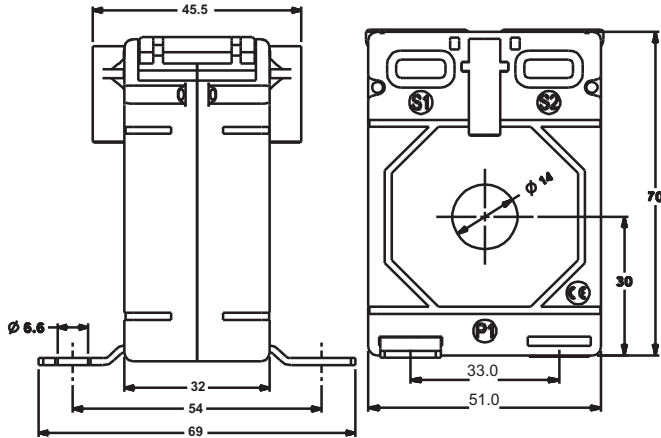

Primary Current	RISH χ mer 50/14 (30)	
	Accuracy	
	0.5	1.0
40A	-	1VA
50A	-	1.5VA
60A	-	1.5VA
75A	-	1.5VA
80A	-	1.5VA
100A	2.5VA	3.75VA
120A	2.5VA	3.75VA
125A	2.5VA	3.75VA
150A	3.75VA	5VA
200A	3.75VA	5VA
250A	5VA	7.5VA
300A	7.5VA	7.5VA

RISH χ mer 50/21 (30)

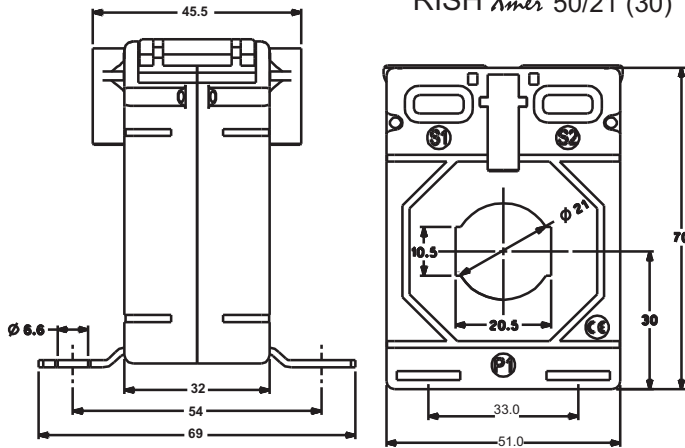

Primary Current	RISH χ mer 50/21 (30)	
	Accuracy	
	0.5	1.0
50A	-	1VA
60A	-	1VA
75A	-	1.5VA
80A	1VA	2.5VA
100A	1.5VA	2.5VA
120A	2.5VA	2.5VA
125A	2.5VA	3.75VA
150A	2.5VA	5VA
200A	3.75VA	5VA
250A	5VA	5VA
300A	5VA	7.5VA
400A	5VA	7.5VA

RISH χ mer 50/30 (30)

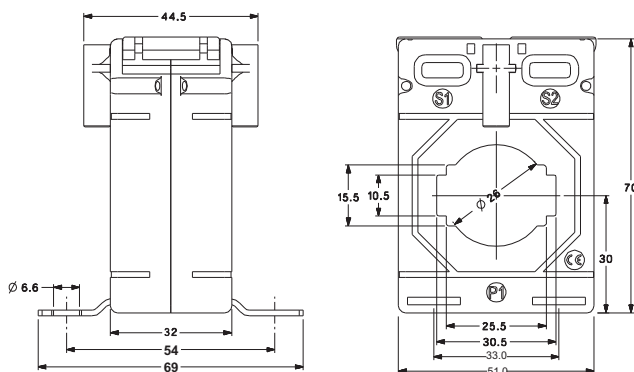

Primary Current	RISH χ mer 50/30 (30)	
	Accuracy	
	0.5	1.0
75A	-	1VA
80A	-	1.5VA
100A	1VA	2.5VA
120A	1VA	2.5VA
125A	1VA	2.5VA
150A	2.5VA	3.75VA
200A	2.5VA	5VA
250A	5VA	5VA
300A	5VA	5VA
400A	5VA	6.25VA
500A	5VA	6.25VA
600A	5VA	7.5VA

ALL DIMENSIONS ARE IN MM



Measure



Control



Record



Analyze



Optimize

RISH λ mer 50/14 (50), 50/21 (50) and 50/30 (50) SERIES

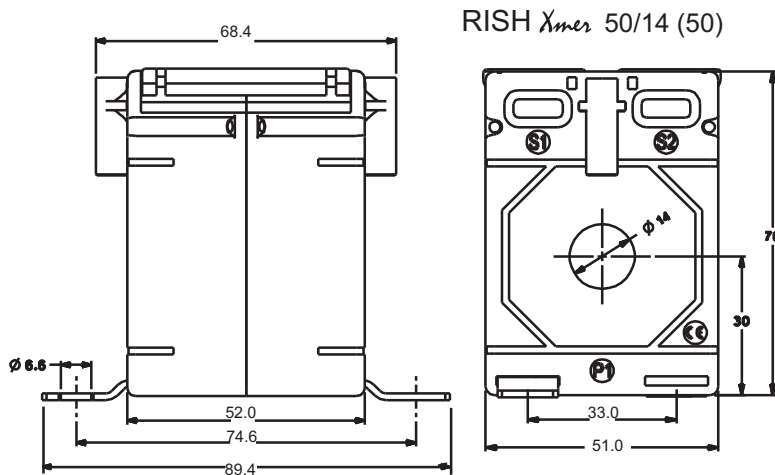

Primary Current	RISH λ mer 50/14 (50)	
	Accuracy	
	0.5	1.0
30A	-	1VA
40A	-	1VA
50A	1.5VA	1.5VA
60A	1.5VA	1.5VA
75A	2.5VA	5VA
80A	2.5VA	5VA
100A	3.75VA	5VA
120A	3.75VA	5VA
125A	3.75VA	5VA
150A	5VA	7.5VA
200A	7.5VA	10VA
250A	10VA	12.5VA
300A	10VA	12.5VA

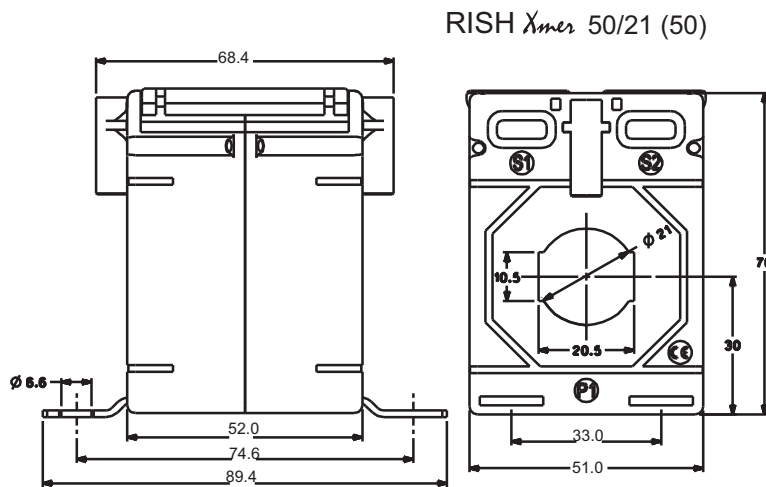

Primary Current	RISH λ mer 50/21 (50)	
	Accuracy	
	0.5	1.0
50A	1VA	2.5VA
60A	1.5VA	3.75VA
75A	1.5VA	3.75VA
80A	2.5VA	5VA
100A	2.5VA	5VA
120A	3.75VA	5VA
125A	5VA	5VA
150A	5VA	10VA
200A	10VA	12.5VA
250A	10VA	15VA
300A	7.5VA	12.5VA
400A	10VA	15VA

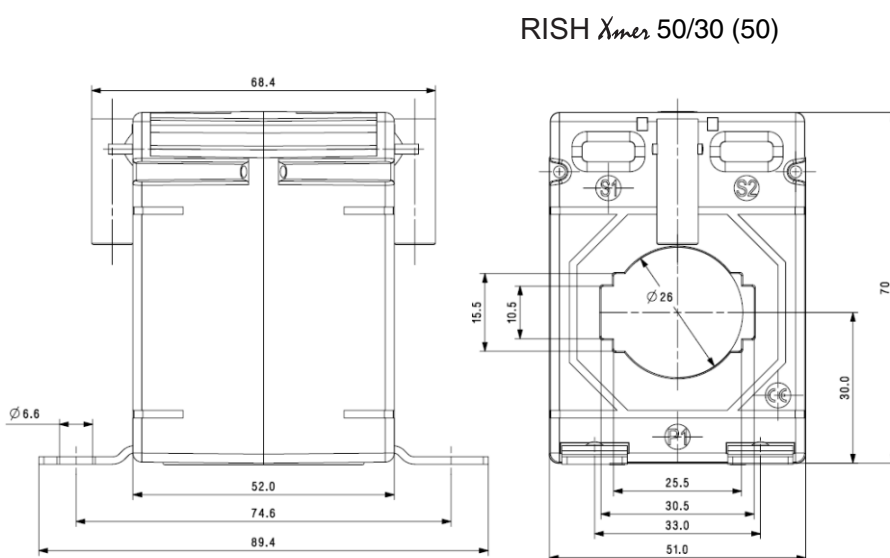

Primary Current	RISH λ mer 50/30 (50)	
	Accuracy	
	0.5	1.0
50A	-	1.5VA
60A	-	1.5VA
75A	-	2.5VA
80A	-	2.5VA
100A	1VA	3.75VA
120A	2.5VA	5VA
125A	2.5VA	5VA
150A	5VA	5VA
200A	5VA	7.5VA
250A	5VA	10VA
300A	5VA	10VA
400A	10VA	12.5VA
500A	10VA	12.5VA
600A	10VA	15VA

ALL DIMENSIONS ARE IN MM



Measure



Control



Record



Analyze



Optimize

RISH χ mer 62 SERIES

RISH χ mer 62/R(40)

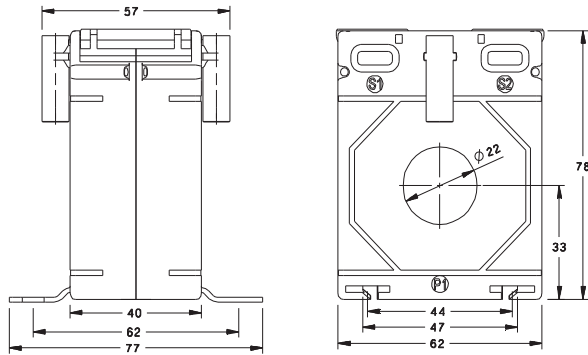

Primary Current	RISH χ mer 62/R(40)			
	Accuracy			
	0.2S/0.5S	0.2	0.5	1.0
50A	-	-	-	1.5VA
60A	-	-	-	2.5VA
75A	-	-	1.5VA	2.5VA
80A	-	-	2.5VA	2.5VA
100A	-	1.5VA	2.5VA	5VA
120A	-	1.5VA	3.75VA	5VA
125A	-	1.5VA	3.75VA	5VA
150A	2.5VA	2.5VA	5VA	7.5VA
200A	5VA	5VA	7.5VA	10VA
250A	5VA	5VA	10VA	15VA
300A	5VA	5VA	10VA	15VA
400A	5VA	10VA	15VA	15VA
500A	10VA	10VA	15VA	15VA
600A	10VA	10VA	15VA	15VA

RISH χ mer 62/20(40)

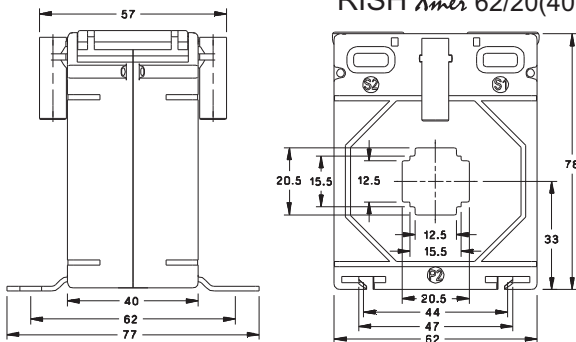

Primary Current	RISH χ mer 62/20(40)			
	Accuracy			
	0.2S/0.5S	0.2	0.5	1.0
50A	-	-	-	1.5VA
60A	-	-	-	2.5VA
75A	-	-	1.5VA	3.75VA
80A	-	-	2.5VA	3.75VA
100A	1.5VA	1.5VA	2.5VA	5VA
120A	1.5VA	1.5VA	3.75VA	5VA
125A	1.5VA	1.5VA	3.75VA	5VA
150A	2.5VA	2.5VA	5VA	7.5VA
200A	3.75VA	5VA	7.5VA	10VA
250A	3.75VA	5VA	10VA	15VA
300A	5VA	5VA	10VA	15VA
400A	5VA	10VA	15VA	15VA
500A	5VA	10VA	15VA	15VA

RISH χ mer 62/30(40)

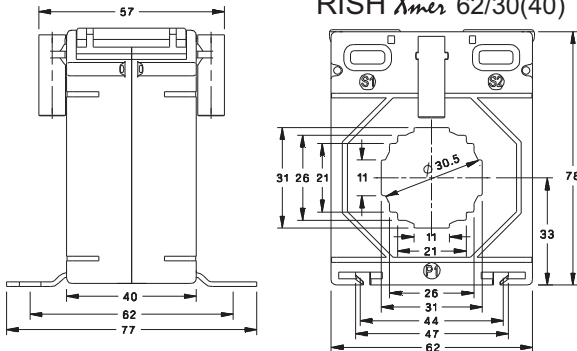

Primary Current	RISH χ mer 62/30(40)			
	Accuracy			
	0.2S/0.5S	0.2	0.5	1.0
50A	-	-	-	1.25VA
60A	-	-	-	1.5VA
75A	-	-	-	2.5VA
80A	-	-	-	2VA
100A	1VA	1VA	1.5VA	3.75VA
120A	1VA	1VA	2.5VA	3.75VA
125A	1VA	1VA	2.5VA	3.75VA
150A	2.5VA	1.5VA	3.75VA	7.5VA
200A	5VA	3.75VA	5VA	10VA
250A	5VA	5VA	5VA	10VA
300A	5VA	3.75VA	10VA	15VA
400A	5VA	10VA	12.5VA	15VA
500A	5VA	10VA	12.5VA	15VA
600A	7.5VA	10VA	15VA	20VA
750A	10VA	10VA	15VA	15VA
800A	10VA	10VA	15VA	15VA

RISH χ mer 62/40(40)

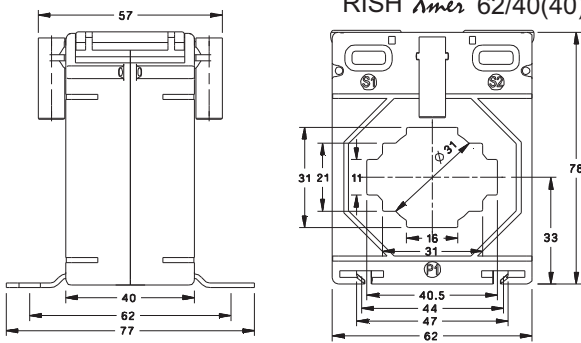

Primary Current	RISH χ mer 62/40(40)			
	Accuracy			
	0.2S/0.5S	0.2	0.5	1.0
100A	-	-	-	1.5VA
120A	-	-	-	1.5VA
125A	-	-	-	1.5VA
150A	-	-	-	2.5VA
200A	1VA	1VA	1.5VA	3.75VA
250A	1.5VA	1.5VA	2.5VA	5VA
300A	1.5VA	1.5VA	5VA	5VA
400A	2.5VA	2.5VA	5VA	5VA
500A	2.5VA	5VA	5VA	7.5VA
600A	2.5VA	7.5VA	7.5VA	10VA
750A	5VA	10VA	10VA	10VA
800A	5VA	10VA	10VA	10VA

RISH χ mer 62/30(50)

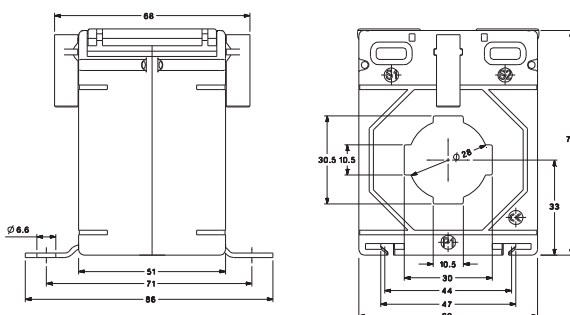

Primary Current	RISH χ mer 62/30(50)			
	Accuracy			
	0.2S/0.5S	0.2	0.5	1.0
50A	-	-	-	1.5VA
60A	-	-	-	2.5VA
75A	-	-	2.5VA	2.5VA
80A	-	-	2.5VA	3.75VA
100A	1.25VA	1.25VA	2.5VA	5VA
120A	1.25VA	1.25VA	5VA	5VA
125A	1.25VA	1.25VA	5VA	5VA
150A	2VA	2VA	5VA	7.5VA
200A	5VA	3.75VA	10VA	15VA
250A	5VA	5VA	15VA	15VA
300A	5VA	5VA	15VA	15VA
400A	10VA	6.25VA	15VA	30VA
500A	5VA	7.5VA	15VA	30VA
600A	6.25VA	10VA	20VA	30VA
750A	6.25VA	10VA	20VA	30VA
800A	6.25VA	10VA	20VA	30VA

RISH χ mer 74 SERIES

RISH χ mer 74/20(45)

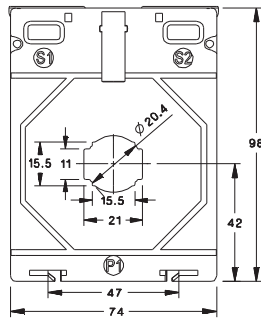
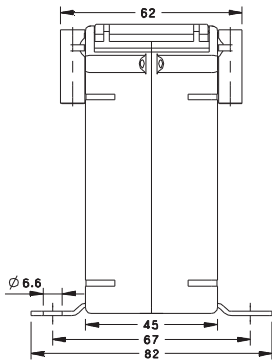

Primary Current	RISH χ mer 74/20(45)			
	Accuracy			
	0.2S/0.5S	0.2	0.5	1.0
40A	-	-	-	1.5VA
50A	-	-	1VA	2.5VA
60A	-	-	1VA	3.75VA
75A	-	-	1.5VA	5VA
80A	-	-	2.5VA	5VA
100A	1.5VA	1.5VA	5VA	7.5VA
120A	1.5VA	1.5VA	5VA	10VA
125A	1.5VA	1.5VA	5VA	10VA
150A	2.5VA	2.5VA	7.5VA	12.5VA
200A	5VA	5VA	10VA	15VA
250A	5VA	5VA	10VA	15VA
300A	5VA	7.5VA	15VA	15VA
400A	5VA	10VA	15VA	20VA
500A	5VA	10VA	15VA	15VA

RISH χ mer 74/30(45)

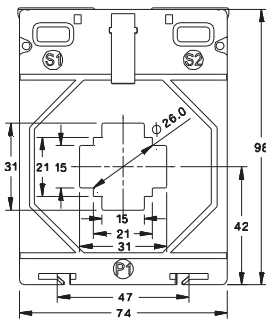
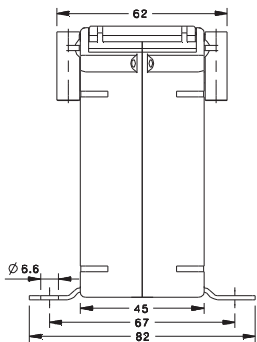

Primary Current	RISH χ mer 74/30(45)			
	Accuracy			
	0.2S/0.5S	0.2	0.5	1.0
40A	-	-	-	1.5VA
50A	-	-	-	1.5VA
60A	-	-	-	2.5VA
75A	-	-	1.5VA	2.5VA
80A	-	-	1.5VA	3.75VA
100A	1.5VA	1.5VA	2.5VA	5VA
120A	1.5VA	1.5VA	2.5VA	5VA
125A	1.5VA	1.5VA	2.5VA	5VA
150A	1.5VA	1.5VA	5VA	7.5VA
200A	2.5VA	2.5VA	10VA	15VA
250A	2.5VA	2.5VA	10VA	15VA
300A	2.5VA	5VA	10VA	15VA
400A	5VA	7.5VA	15VA	20VA
500A	5VA	10VA	15VA	20VA
600A	5VA	15VA	15VA	20VA
750A	7.5VA	20VA	20VA	30VA
800A	10VA	30VA	30VA	30VA

RISH χ mer 74/40(45)

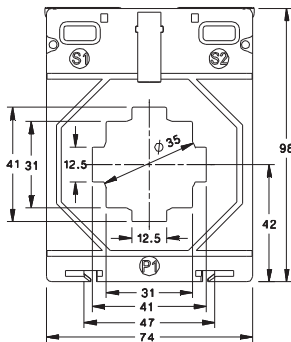
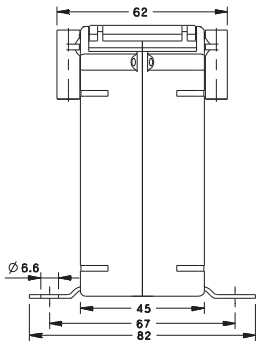

Primary Current	RISH χ mer 74/40(45)			
	Accuracy			
	0.2S/0.5S	0.2	0.5	1.0
40A	-	-	-	1VA
50A	-	-	-	1.5VA
60A	-	-	-	1.5VA
75A	-	-	-	2.5VA
80A	-	-	-	2.5VA
100A	1VA	-	1.5VA	3.75VA
120A	1VA	-	1.5VA	2.5VA
125A	1VA	-	1.5VA	2.5VA
150A	1.5VA	1VA	3.75VA	5VA
200A	2.5VA	2.5VA	5VA	10VA
250A	5VA	3.75VA	5VA	10VA
300A	5VA	5VA	10VA	15VA
400A	5VA	10VA	10VA	15VA
500A	5VA	10VA	15VA	20VA
600A	5VA	15VA	15VA	20VA
750A	5VA	15VA	15VA	20VA
800A	7.5VA	15VA	15VA	20VA
1000A	10VA	15VA	15VA	20VA

RISH χ mer 74/50(45)

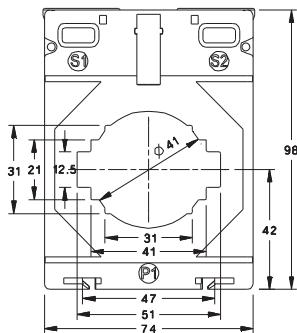
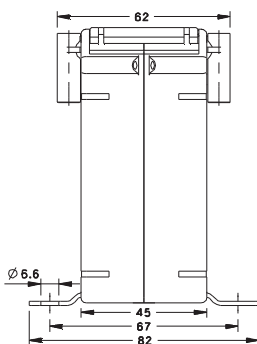

Primary Current	RISH χ mer 74/50(45)			
	Accuracy			
	0.2S/0.5S	0.2	0.5	1.0
100A	-	-	-	1.5VA
120A	-	-	-	1.5VA
125A	-	-	-	1.5VA
150A	-	-	-	2.5VA
200A	-	-	1.5VA	3.75VA
250A	1.5VA	1.5VA	2.5VA	5VA
300A	1.5VA	1.5VA	5VA	7.5VA
400A	2.5VA	2.5VA	5VA	7.5VA
500A	5VA	5VA	7.5VA	10VA
600A	5VA	7.5VA	10VA	12.5VA
750A	5VA	10VA	12.5VA	15VA
800A	5VA	10VA	12.5VA	15VA
1000A	5VA	10VA	12.5VA	15VA

ALL DIMNSIONS ARB IN MM



Measure



Control



Record



Analyze



Optimize

RISH λ mer 86 SERIES

RISH λ mer 86/40(45)

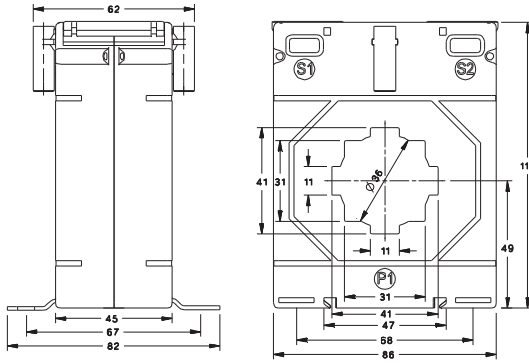

Primary Current	RISH λ mer 86/40(45)			
	Accuracy			
	0.2S/0.5S	0.2	0.5	1.0
50A	-	-	-	1.5VA
60A	-	-	-	1.5VA
75A	-	-	-	2.5VA
80A	-	-	-	2.5VA
100A	1.5VA	1.5VA	2.5VA	5VA
120A	1.5VA	1.5VA	2.5VA	5VA
125A	1.5VA	1.5VA	2.5VA	5VA
150A	2.5VA	2.5VA	5VA	10VA
200A	5VA	2.5VA	7.5VA	15VA
250A	10VA	5VA	7.5VA	15VA
300A	10VA	10VA	15VA	15VA
400A	10VA	15VA	15VA	20VA
500A	5VA	15VA	30VA	30VA
600A	7.5VA	15VA	30VA	30VA
750A	7.5VA	15VA	30VA	30VA
800A	10VA	15VA	30VA	30VA
1000A	10VA	15VA	30VA	30VA

RISH λ mer 86/50(45)

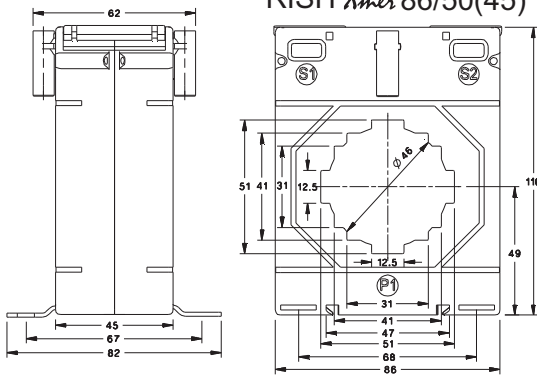

Primary Current	RISH λ mer 86/50(45)			
	Accuracy			
	0.2S/0.5S	0.2	0.5	1.0
100A	-	-	1VA	1.5VA
120A	-	-	1.5VA	2.5VA
125A	-	-	1.5VA	2.5VA
150A	-	-	2.5VA	5VA
200A	2.5VA	1VA	5VA	7.5VA
250A	2.5VA	1.5VA	7.5VA	10VA
300A	5VA	3.75VA	7.5VA	10VA
400A	7.5VA	10VA	15VA	15VA
500A	7.5VA	10VA	15VA	20VA
600A	10VA	15VA	15VA	20VA
750A	7.5VA	15VA	15VA	20VA
800A	10VA	12.5VA	20VA	30VA
1000A	12.5VA	20VA	30VA	30VA
1200A	12.5VA	20VA	30VA	30VA
1250A	12.5VA	20VA	30VA	30VA

RISH λ mer 86/60(45)

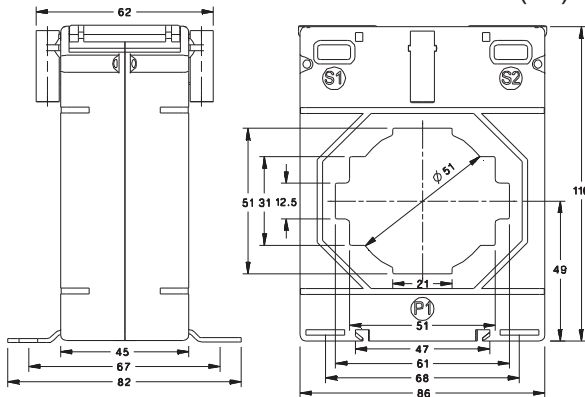

Primary Current	RISH λ mer 86/60(45)			
	Accuracy			
	0.2S/0.5S	0.2	0.5	1.0
100A	-	-	-	1VA
120A	-	-	-	1.5VA
125A	-	-	-	2.5VA
150A	-	-	-	2.5VA
200A	-	-	1.5VA	3.75VA
250A	-	-	2.5VA	5VA
300A	1.5VA	1.5VA	5VA	7.5VA
400A	2.5VA	2.5VA	10VA	12.5VA
500A	2.5VA	3.75VA	10VA	15VA
600A	5VA	5VA	15VA	15VA
750A	5VA	10VA	15VA	20VA
800A	7.5VA	12.5VA	20VA	20VA
1000A	10VA	15VA	20VA	30VA
1200A	10VA	15VA	20VA	30VA
1250A	10VA	15VA	20VA	20VA
1500A	10VA	15VA	20VA	20VA
1600A	10VA	15VA	20VA	20VA

RISH λ mer 86/63(45)

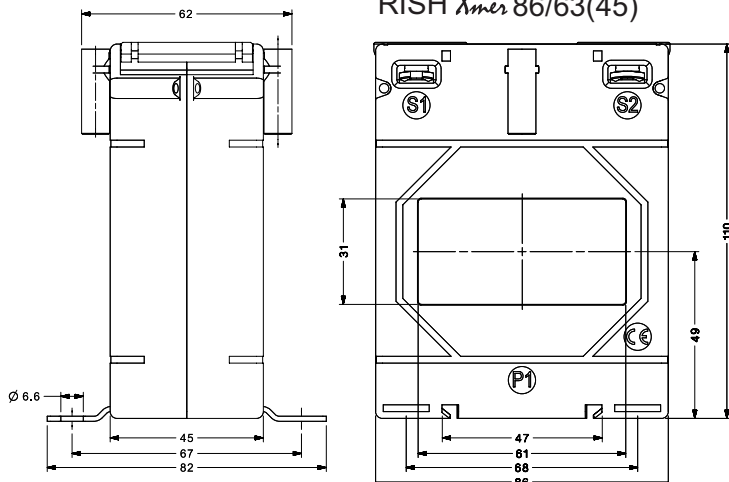

Primary current (A)	RISH λ mer 86/63(45)			
	Accuracy class			
	0.5S	0.2	0.5	1.0
400	1.5 VA	-	5 VA	10 VA
500	1.5 VA	-	6.25 VA	10 VA
600	2.5 VA	1 VA	7.5 VA	12.5 VA
750	5 VA	3.75 VA	10 VA	15 VA
800	5 VA	3.75 VA	10 VA	15 VA
1000	7.5 VA	5 VA	10 VA	15 VA
1200	7.5 VA	5 VA	10 VA	15 VA
1250	7.5 VA	5 VA	10 VA	15 VA
1500	10 VA	7.5 VA	12.5 VA	15 VA
1600	10 VA	7.5 VA	12.5 VA	15 VA

ALL DIMENSIONS ARE IN MM

RISH *Xmer* 100/100V(45)

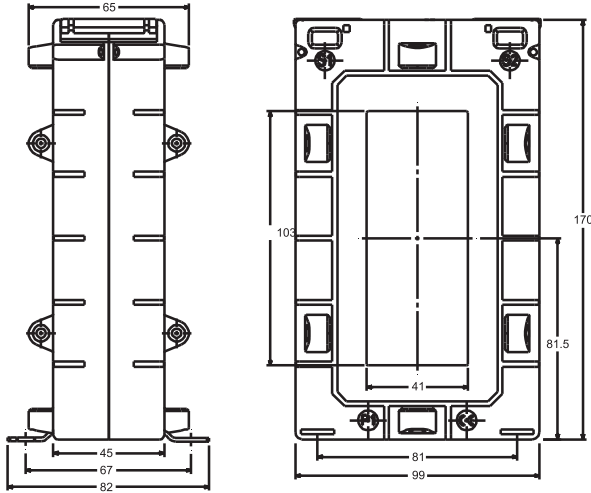

Primary Current	RISH <i>Xmer</i> 100/100V(45)			
	Accuracy			
	0.2S/0.5S	0.2	0.5	1.0
400A	-	-	2.5VA	5VA
500A	-	-	2.5VA	5VA
600A	-	-	2.5VA	5VA
750A	-	-	2.5VA	5VA
800A	-	-	5VA	10VA
1000A	-	5VA	10VA	15VA
1200A	5VA	5VA	10VA	15VA
1250A	5VA	5VA	10VA	15VA
1500A	5VA	5VA	15VA	30VA
1600A	7.5VA	10VA	15VA	30VA
2000A	7.5VA	10VA	15VA	30VA
2500A	10VA	10VA	15VA	20VA

RISH *Xmer* 100/130V(45)

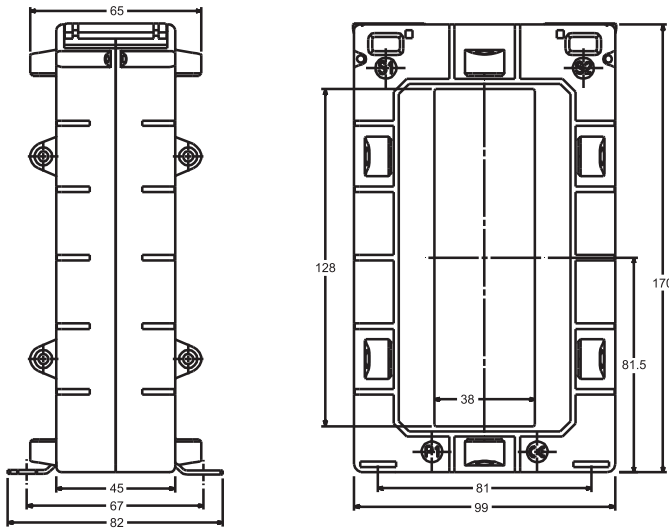

Primary Current	RISH <i>Xmer</i> 100/130V(45)		
	Accuracy		
	0.2	0.5	1.0
400A	-	2.5VA	5VA
500A	-	2.5VA	5VA
600A	-	2.5VA	5VA
750A	-	2.5VA	5VA
800A	-	5VA	10VA
1000A	-	10VA	15VA
1200A	-	10VA	15VA
1250A	-	10VA	15VA
1500A	5VA	15VA	30VA
1600A	5VA	15VA	30VA
2000A	5VA	15VA	30VA
2500A	5VA	15VA	30VA
3200A	5VA	10VA	12.5VA

RISH *Xmer* 130/100V(50)

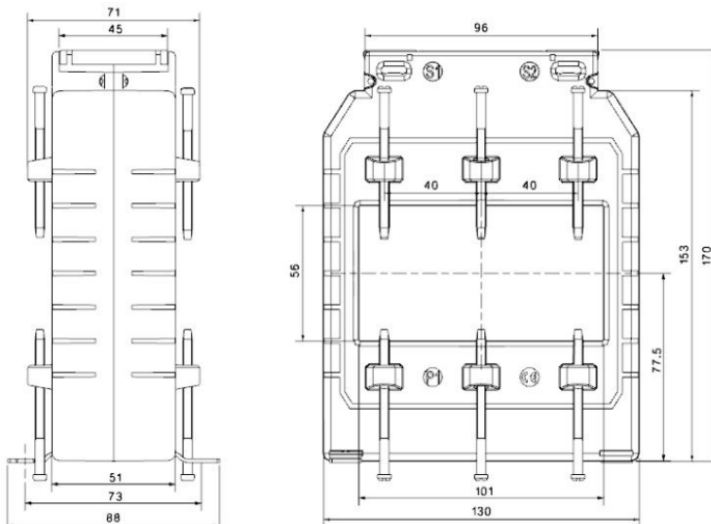

Primary Current	RISH <i>Xmer</i> 130/100V(50)			
	Accuracy			
	0.2S/0.5S	0.2	0.5	1.0
600A	2.5VA	2.5VA	5VA	10VA
750A	3.75VA	5VA	10VA	10VA
800A	5VA	7.5VA	10VA	10VA
1000A	7.5VA	10VA	15VA	15VA
1200A	10VA	10VA	15VA	15VA
1250A	10VA	10VA	15VA	15VA
1500A	10VA	15VA	15VA	15VA
1600A	10VA	15VA	15VA	15VA
2000A	10VA	15VA	15VA	15VA
2500A	10VA	15VA	15VA	15VA
3000A	12.5VA	15VA	15VA	15VA

ALL DIMENSIONS ARE IN MM

RISH *X*mer 104 SERIES

RISH *X*mer 104/60(45)

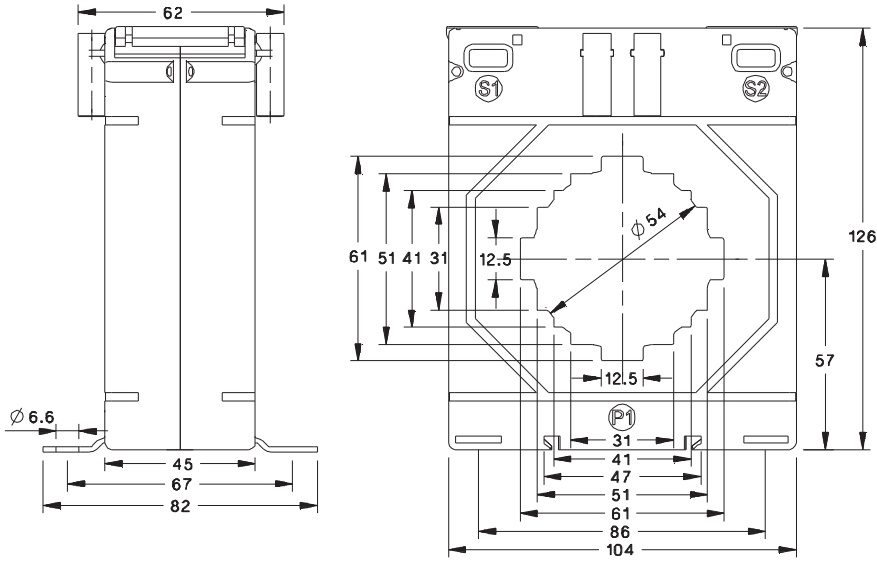

Primary Current	RISH <i>X</i> mer 104/60(45)			
	Accuracy			
	0.2S/0.5S	0.2	0.5	1.0
100A	-	-	-	1.5VA
120A	-	-	-	2.5VA
125A	-	-	-	2.5VA
150A	-	-	2.5VA	5VA
200A	-	1VA	5VA	10VA
250A	-	2.5VA	7.5VA	12.5VA
300A	1.5VA	3.75VA	10VA	15VA
400A	2.5VA	7.5VA	10VA	15VA
500A	7.5VA	10VA	15VA	20VA
600A	15VA	15VA	15VA	30VA
750A	15VA	15VA	20VA	30VA
800A	15VA	15VA	30VA	30VA
1000A	15VA	20VA	30VA	45VA
1200A	15VA	30VA	30VA	45VA
1250A	15VA	30VA	30VA	45VA
1500A	15VA	30VA	30VA	45VA
1600A	15VA	30VA	30VA	45VA

RISH *X*mer 104/80(45)

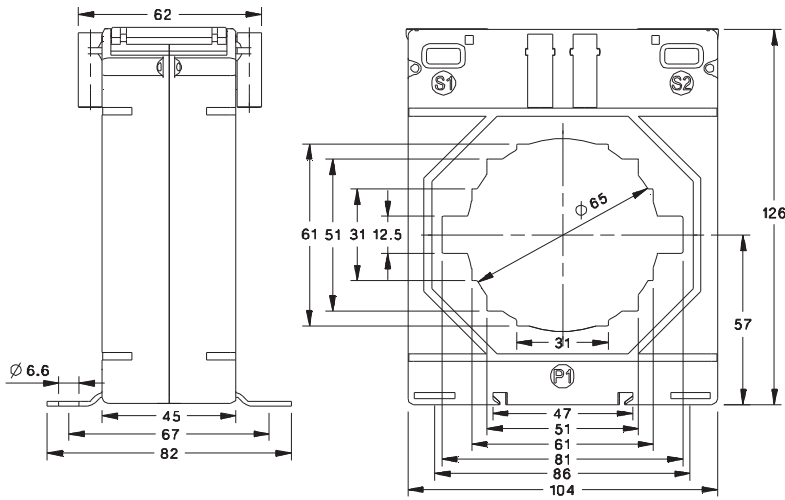

Primary Current	RISH <i>X</i> mer 104/80(45)			
	Accuracy			
	0.2S/0.5S	0.2	0.5	1.0
200A	-	-	-	1.5VA
250A	-	-	1.5VA	2.5VA
300A	-	-	2.5VA	7.5VA
400A	-	1.5VA	7.5VA	10VA
500A	-	5VA	10VA	10VA
600A	3.75VA	5VA	10VA	12.5VA
750A	5VA	5VA	15VA	15VA
800A	5VA	7.5VA	15VA	15VA
1000A	15VA	12.5VA	20VA	30VA
1200A	15VA	15VA	20VA	30VA
1250A	15VA	15VA	20VA	30VA
1500A	15VA	15VA	20VA	30VA
1600A	10VA	15VA	20VA	30VA
2000A	10VA	15VA	20VA	30VA



Measure



Control



Record



Analyze



Optimize

ALL DIMENSIONS ARE IN MM

RISH *χ*mer 140 SERIES

RISH *χ*mer 140/80(45)

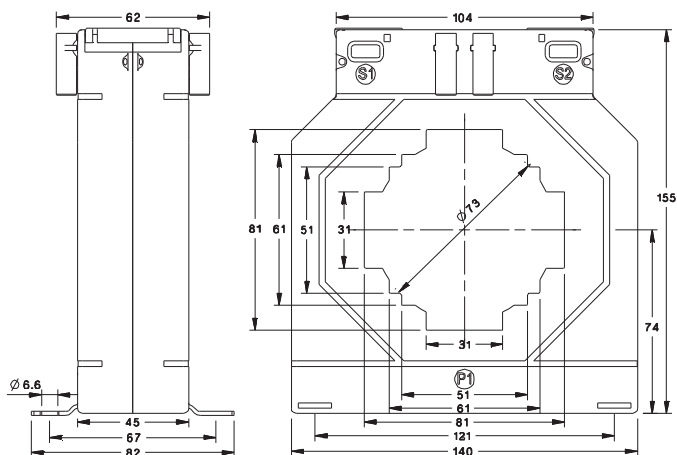

Primary Current	RISH <i>χ</i> mer 140/80(45)			
	Accuracy			
	0.2S/0.5S	0.2	0.5	1.0
200A	-	-	2.5VA	5VA
250A	-	-	5VA	10VA
300A	-	1.5VA	7.5VA	15VA
400A	-	2.5VA	10VA	20VA
500A	2.5VA	5VA	15VA	30VA
600A	3.75VA	7.5VA	15VA	30VA
750A	5VA	10VA	15VA	45VA
800A	5VA	10VA	15VA	45VA
1000A	10VA	15VA	30VA	60VA
1200A	12.5VA	15VA	30VA	60VA
1250A	12.5VA	30VA	60VA	60VA
1500A	15VA	30VA	60VA	60VA
1600A	15VA	30VA	60VA	60VA
2000A	15VA	30VA	60VA	60VA

RISH *χ*mer 140/80H (45)

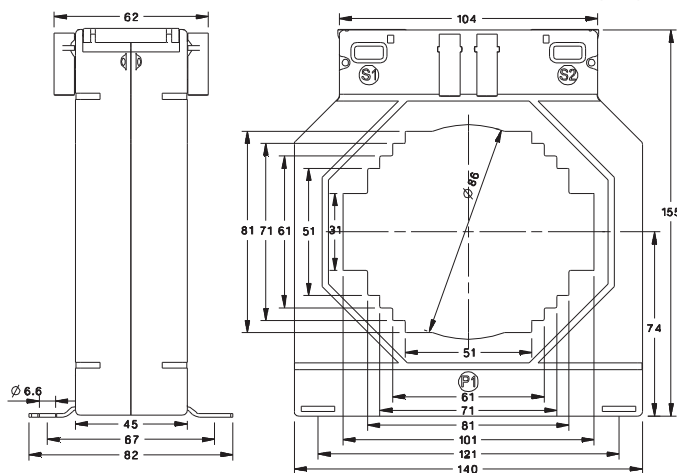

Primary Current	RISH <i>χ</i> mer 140/80H (45)			
	Accuracy			
	0.2S/0.5S	0.2	0.5	1.0
200A	-	-	1.5VA	3.75VA
250A	-	-	2.5VA	5VA
300A	-	-	3.75VA	7.5VA
400A	-	1.5VA	7.5VA	10VA
500A	-	2.5VA	10VA	12.5VA
600A	2.5VA	3.75VA	10VA	15VA
750A	5VA	5VA	15VA	20VA
800A	5VA	5VA	15VA	20VA
1000A	5VA	10VA	15VA	20VA
1200A	10VA	15VA	15VA	30VA
1250A	10VA	15VA	15VA	30VA
1500A	15VA	20VA	20VA	30VA
1600A	15VA	20VA	20VA	45VA
2000A	15VA	30VA	45VA	45VA
2500A	15VA	30VA	45VA	45VA
3000A	15VA	30VA	60VA	60VA
4000A	15VA	30VA	60VA	60VA

RISH *χ*mer 140/100V(45)

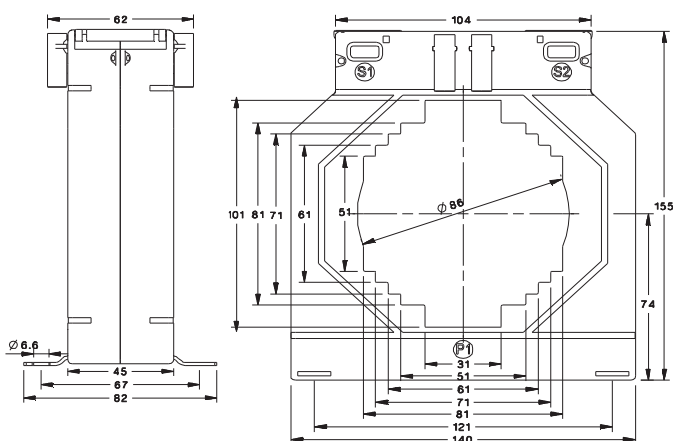

Primary Current	RISH <i>χ</i> mer 140/100V(45)			
	Accuracy			
	0.2S/0.5S	0.2	0.5	1.0
200A	-	-	1.5VA	3.75VA
250A	-	-	2.5VA	5VA
300A	-	-	3.75VA	7.5VA
400A	-	1.5VA	10VA	10VA
500A	-	2.5VA	10VA	12.5VA
600A	2.5VA	3.75VA	12.5VA	15VA
750A	5VA	5VA	15VA	20VA
800A	5VA	5VA	15VA	20VA
1000A	5VA	10VA	15VA	20VA
1200A	10VA	15VA	15VA	30VA
1250A	10VA	15VA	15VA	30VA
1500A	15VA	20VA	30VA	30VA
1600A	15VA	20VA	45VA	45VA
2000A	15VA	30VA	45VA	45VA
2500A	15VA	30VA	45VA	45VA
3000A	15VA	30VA	60VA	60VA

ALL DIMENSIONS ARE IN MM



Measure



Control



Record



Analyze



Optimize

RISH χ mer 140/130V (45)

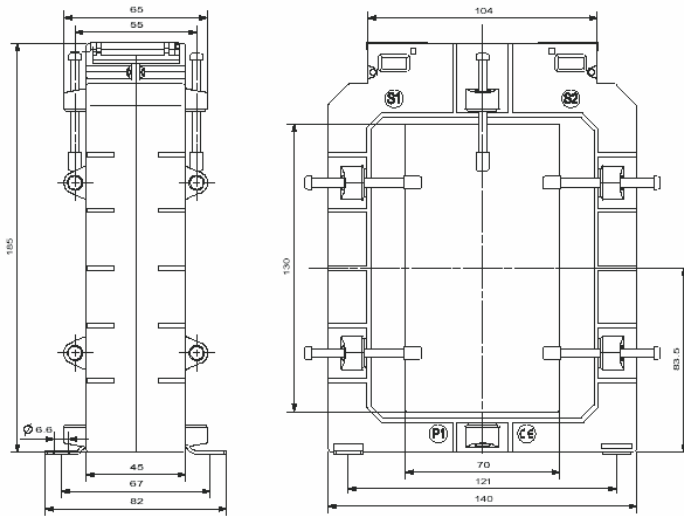

Primary Current	RISH χ mer 140/130V (45)		
	Accuracy		
	0.2	0.5	1.0
400A	-	3.75VA	5VA
500A	-	3.75VA	5VA
600A	-	3.75VA	5VA
750A	-	5VA	7.5VA
800A	-	5VA	7.5VA
1000A	5VA	10VA	10VA
1200A	7.5VA	10VA	15VA
1250A	7.5VA	10VA	15VA
1500A	10VA	15VA	15VA
1600A	10VA	15VA	15VA
2000A	15VA	20VA	20VA
2500A	15VA	20VA	20VA
3000A	15VA	20VA	20VA
3200A	15VA	20VA	20VA
4000A	15VA	20VA	20VA
5000A	15VA	20VA	20VA

RISH χ mer 225 SERIES

RISH χ mer 225/125 (50)

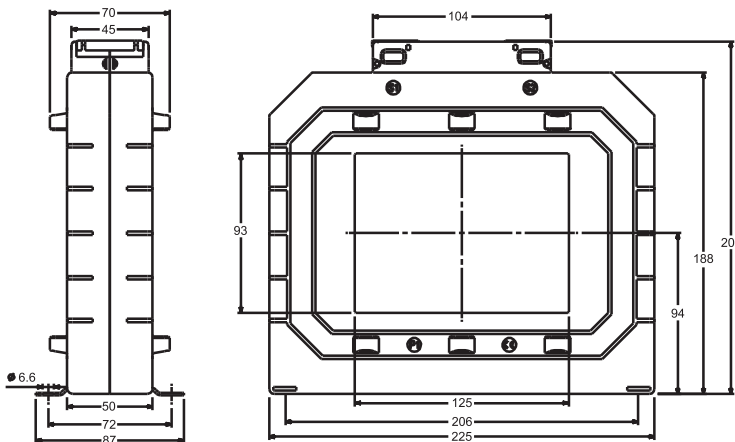

Primary Current	RISH χ mer 225/125 (50)			
	Accuracy			
	0.2S/0.5S	0.2	0.5	1.0
600A	-	5VA	5VA	10VA
750A	-	5VA	10VA	10VA
800A	-	5VA	10VA	10VA
1000A	5VA	10VA	10VA	15VA
1200A	5VA	10VA	10VA	15VA
1250A	5VA	10VA	10VA	15VA
1500A	7.5VA	10VA	15VA	30VA
1600A	7.5VA	10VA	15VA	30VA
2000A	10VA	10VA	15VA	30VA
2500A	10VA	15VA	30VA	30VA
3000A	10VA	15VA	30VA	60VA
4000A	15VA	30VA	45VA	60VA
5000A	15VA	30VA	100VA	100VA
6000A	15VA	60VA	100VA	100VA

RISH χ mer 225/167 (50)

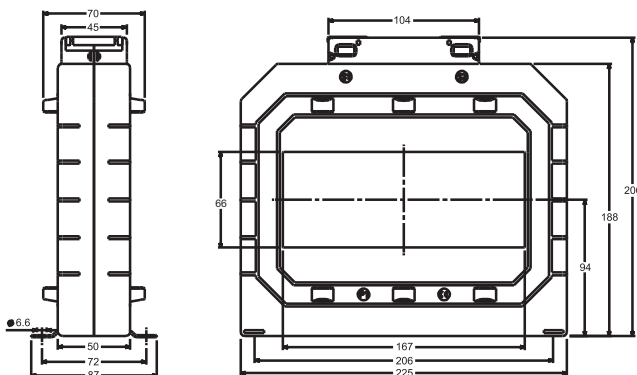

Primary Current	RISH χ mer 225/167 (50)			
	Accuracy			
	0.2S/0.5S	0.2	0.5	1.0
1000A	-	3.75VA	5VA	10VA
1200A	-	5VA	10VA	15VA
1250A	-	5VA	10VA	15VA
1500A	5VA	10VA	15VA	30VA
1600A	5VA	10VA	15VA	30VA
2000A	7.5VA	10VA	30VA	30VA
2500A	10VA	15VA	30VA	45VA
3000A	10VA	15VA	30VA	45VA
4000A	10VA	15VA	30VA	45VA
5000A	15VA	20VA	30VA	45VA
6000A	15VA	20VA	30VA	45VA
7500A	15VA	20VA	30VA	45VA

ALL DIMENSIONS ARE IN MM



RISHABH



Measure



Control



Record



Analyze



Optimize

RISHABH INSTRUMENTS LIMITED

Domestic (India): +91 253 2202099 | marketing@rishabh.co.in
International: +91 253 2202004/06/08/99 | global@rishabh.co.in
www.rishabh.co.in