



Data Sheet

RISH DMCI

Demand Controller



Measure



Control



Record



Analyze



Optimize

RISH DMCi is a smart Demand Monitor and controller which controls the Active, Reactive, Apparent or Current Demand within the allowed limits and helps to save money on utility bills. This instrument prevents consumption of excess power or peaks resulting in higher penalties. It provides the simulation feature allowing one to enter the load values and verify the system conditions prior to installation.

Product Features

Demand Measurement and Control

- W, Var, VA and Current Demand
- Controlling with any selected parameter
- Selectable window type - Fixed or Sliding
- Demand Period selectable from 1 to 60 minutes
- Predictive Demand Control for faster controlling action even before completion of present demand interval
- Demand Control with separate load shedding thresholds for each tariff zone
- All Max Demand (W, VAR, VA & Current) parameters are stored with Date and Time stamp
- OLD Max Demand Storage

Control Outputs

4 Relay Outputs for efficient Demand Control and Management

Measures & Monitors more than 80 parameters

- All basic electrical parameters
- Individual harmonics contents of per phase voltage and current.
- Onsite programmable CT ratio & PT ratio and system configuration
- Wide auxiliary power supply range: 60-300VAC/DC

True RMS measurement

The instrument measures distorted waveform upto 56th Harmonic for 50Hz and upto 46th Harmonic for 60Hz

Power Quality Measurement

- Measurable up to 56th (50Hz) harmonic on each phase. Maximum any 6 harmonics can be monitored simultaneously for each phase
- Measurement of RMS value of fundamental and per phase voltage and current harmonics
- (%) THD of per phase voltage and current
- Distortion factor of individual harmonics

Real Time Clock (RTC)

Displays date and time

Run Hour, ON Hour, Number of Interruptions

Displays parameters for both mode utility and generator

Graphical Analysis

- Per phase individual harmonic bar graph representation.
- Real time vector representation of all 3 Phases for complete system analysis

Energy 0.5S as per IEC 62053

- Independent Import and Export energy counter
- Active energy (kWh), Fundamental Reactive energy (kVARh) and Apparent energy (kVAh) measurement
- Accuracy Class 0.5S as per IEC 62053-22, IEC62053-23

Time Of DAY (TOD / TOU)

- Easy programmable tariff schedule
- 4 seasons, 4 tariffs, 6 time zones per day, 4 types of days, 5 tariff energy register
- Automatic daily profile storage for a one day, one month & one year
- Cost per kWh calculation

Direct remote access via MODBUS

- Remote access of measured and configuration parameters
- User Assignable Registers for MODBUS
- Programmable baud rates up to 38.4kbps

Custom color setting

User can assign individual colour for each phase as per the application requirement through display and MODBUS

Onsite programmable for user desired application

- Onsite programmable input voltage ($100V_{LL}$ to $500 V_{LL}$), input current (1A or 5A) and system configuration (3 phase 4Wire (unbalanced) or 3phase 3Wire (unbalanced) network)
- Onsite programmable CT ratio & PT ratio
- Wide auxiliary power supply range: 60-300VAC/DC

Old Register

this register holds the value before the last reset . The old value will be available when scrolled through screen

Compliance to International Safety standards

compliance to International Safety standard IEC 61010-1-2010

EMC Compatibility

Compliance to International standard IEC 61326



Measure



Control



Record



Analyze



Optimize

Dimensions Details

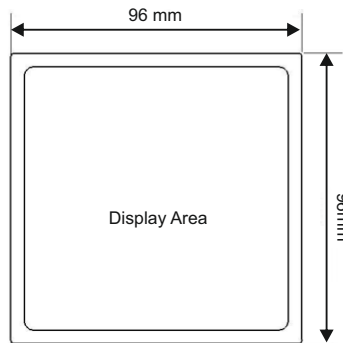

Front View

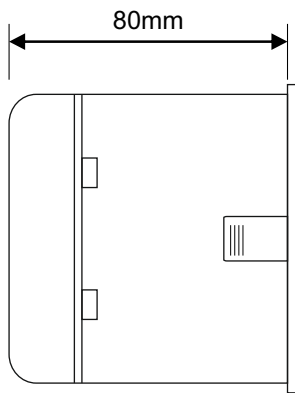

Side View

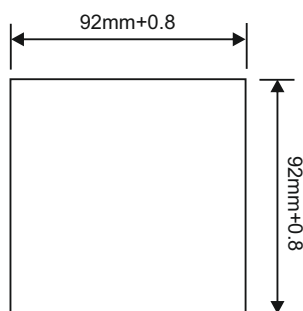

Panel Cutout

Technical Specifications:

Accuracy

Active Energy	Class 0.5S as per IEC 62053 - 22
Apparent Energy	Class 0.5S as per IEC 62053 - 22
Fundamental Reactive Energy	Class 2 as per IEC 62053 - 23
Reference conditions (As per. IEC/EN 60688)	Ambient 23°C ± 1°C Sinusoidal (distortion factor 0.005), 50 / 60 Hz
Active Power	±0.2% of Nominal value
Fundamental Reactive Power	±0.2% of Nominal value
Apparent Power	±0.2% of Nominal value
Power Factor / Phase Angle	±2°
Voltage	±0.2% of Nominal value
Current	±0.2% of Nominal value
Frequency	±0.1% of mid frequency
Harmonics	±1.0%
THD Voltage / Current	±1.0%

Input Voltage

Nominal input voltage (AC RMS)	57.7 - 288.68 V _{LN} On site Programmable (Line-Line 100 - 500 V _{LL})
System PT primary values	100V _{LL} to 692.8 kV _{LL} On site Programmable
Max continuous input voltage	347 V _{LN} , 600 V _{LL}
Voltage Measuring Range	5 V _{LN} ... 347 V _{LN} , 9 V _{LL} ... 600 V _{LL} .
Overload Withstand	2x times of Nominal voltage for 1 second, repeated 10 times at 10 second intervals
Frequency Measuring Range	45Hz to 66Hz

Input Current

Nominal input current	1A / 5AAC RMS On site Programmable
System CT primary values	From 1A up to 9999A On site Programmable
Max continuous input current	120% of Nominal value
Current Measuring Range	5% to 120% of Nominal current.
Overload Withstand	20x times of Nominal current for 1 second, repeated 5 times at 5 min intervals
Starting Current for energy as per IEC 62053-22 class 0.5S	1 mA for 1A range 5 mA for 5A range

Auxiliary Supply

External Aux	60 V – 300V AC-DC
Aux supply frequency	50 / 60 Hz (± 10 %)

VA Burden

Nominal input voltage burden	< 0.2 VA approx. per phase
Nominal input current burden	< 0.2 VA approx. per phase
Auxiliary Supply burden	< 6.5 VA approx

Real Time Clock (RTC)

Uncertainty	± 2 minutes / month (23°C ± 1°C) (trimmable through display or Modbus)
-------------	---



Measure



Control



Record



Analyze



Optimize

Electrical Connections

Network Types :

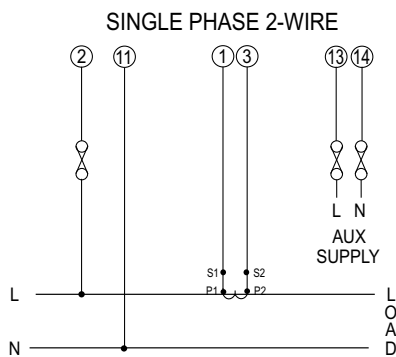
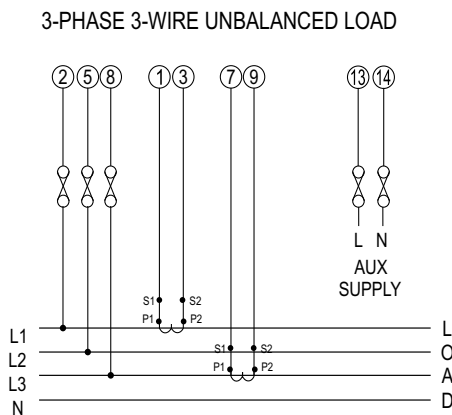
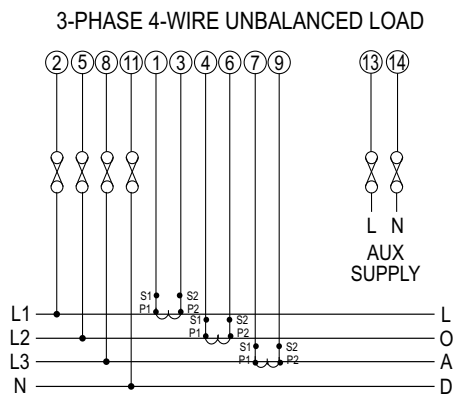

It is recommended that the wires used for connections to the instrument should have lugs soldered at the end. That is, the connections should be made with Lugged wires for secure connections. The Maximum diameter of the lug should be 7.0 mm and maximum thickness 3.5mm.

Technical Specifications

Display Update Rate

Response time to step input 1 sec approx

Applicable Standards

EMC IEC 61326
 Immunity IEC 61000-4-3, 10V/m min – Level 3 industrial Low level
 Safety IEC 61010-1-2010 , Permanently connected use (IP 54 for Front) IEC60529
 IP for water & dust 2
 Pollution degree III
 Installation category 5.23 kV DC between all other Electrical circuits
 High Voltage Test (DC, 1 minute)

Environmental Conditions, Other information

Operating temperature -10 to +55°C
 Storage temperature -20 to +65°C
 Relative humidity 0... 95% non condensing
 Warm up time Minimum 3 minute
 Shock 15g in 3 planes
 Vibration 10... 150.... 10 Hz, 0.075mm amplitude
 Number of Sweep Cycles 0.05%/°C

Interfaces

Relay Used as Control Output
 Load Capacity 240V AC, 5A
 Contact Change over contact, bistable
 Mechanical Endurance 1 x 10⁵ operations
 Electrical Endurance (240V, 5A) 1 x 10⁵ operations
 MODBUS / RTU RS485, max. 1200m
 Baud rate: 4.8k, 9.6k, 19.2k, 38.4k bps



Measure



Control



Record



Analyze



Optimize

Display Parameter

✓ : Available * : Not Available

Sr No	Displayed Parameters	3 Phase 4Wire	3Phase 3Wire	1 Phase 2Wire
1.	System Voltage	✓	✓	✓
2.	System Current	✓	✓	✓
3.	Volts L1 – N	✓	*	✓
4.	Volts L2 – N	✓	*	*
5.	Volts L3 – N	✓	*	*
6.	Volts L1 – L2	✓	✓	*
7.	Volts L2 – L3	✓	✓	*
8.	Volts L3 – L1	✓	✓	*
9.	Current L1	✓	✓	✓
10.	Current L2	✓	✓	*
11.	Current L3	✓	✓	*
12.	Neutral Current	✓	*	*
13.	Frequency	✓	✓	✓
14.	System Active Power (kW)	✓	✓	✓
15.	Active Power L1 (kW)	✓	*	✓
16.	Active Power L2 (kW)	✓	*	*
17.	Active Power L3 (kW)	✓	*	*
18.	System Fundamental Reactive Power (kVAr)	✓	✓	✓
19.	Fundamental Reactive Power L1 (kVAr)	✓	*	✓
20.	Fundamental Reactive Power L2 (kVAr)	✓	*	*
21.	Fundamental Reactive Power L3 (kVAr)	✓	*	*
22.	System Apparent Power (kVA)	✓	✓	✓
23.	Apparent Power L1 (kVA)	✓	*	✓
24.	Apparent Power L2 (kVA)	✓	*	*
25.	Apparent Power L3 (kVA)	✓	*	*
26.	System Power Factor	✓	✓	✓
27.	Power Factor L1	✓	*	✓
28.	Power Factor L2	✓	*	*
29.	Power Factor L3	✓	*	*
30.	Phase Angle L1	✓	*	✓
31.	Phase Angle L2	✓	*	*
32.	Phase Angle L3	✓	*	*
33.	Import kWh (Up to 14 digit resolution)	✓	✓	✓
34.	Export kWh (Up to 14 digit resolution)	✓	✓	✓
35.	Fundamental Import kVArh (Up to 14 digit resolution)	✓	✓	✓
36.	Fundamental Export kVArh (Up to 14 digit resolution)	✓	✓	✓
37.	kVAh (Up to 14 digit resolution)	✓	✓	✓
38.	Current Demand	✓	✓	✓
39.	kVA Demand	✓	✓	✓
40.	kW Import Demand	✓	✓	✓
41.	kW Export Demand	✓	✓	✓
42.	Fundamental Import kVAr Demand	✓	✓	✓
43.	Fundamental Export kVAr Demand	✓	✓	✓
44.	Max Current Demand	✓	✓	✓
45.	Max kVA Demand	✓	✓	✓
46.	Max kW Import Demand	✓	✓	✓
47.	Max kW Export Demand	✓	✓	✓
48.	Max Fundamental Import kVAr Demand	✓	✓	✓
49.	Max Fundamental Export kVAr Demand	✓	✓	✓
50.	Run Hour	✓	✓	✓



Measure



Control



Record



Analyze



Optimize

Display Parameter

✓ : Available * : Not Available

Sr No	Displayed Parameters	3 Phase 4Wire	3Phase 3Wire	1 Phase 2Wire
51.	On Hour	✓	✓	✓
52.	Number of Interruption	✓	✓	✓
53.	Phase Reversal Indication	✓	*	*
54.	Phasor Diagram	✓	*	✓
55.	Voltage Waveform	✓	✓	✓
56.	Current Waveform	✓	✓	✓
57.	% THD Voltage L1-N	✓	*	✓
58.	% THD Voltage L2-N	✓	*	*
59.	% THD Voltage L3-N	✓	*	*
60.	% THD Voltage L1-L2	*	✓	*
61.	% THD Voltage L2-L3	*	✓	*
62.	% THD Voltage L3-L1	*	✓	*
63.	% THD Current L1	✓	✓	✓
64.	% THD Current L2	✓	*	*
65.	% THD Current L3	✓	✓	*
66.	% THD Voltage Mean	✓	✓	*
67.	% THD Current Mean	✓	✓	*
68.	RMS voltage of Harmonics	✓	✓	✓
69.	RMS Current of Harmonics	✓	✓	✓
70.	Fundamental Active Power per phase	✓	*	✓
71.	Fundamental Reactive Power per phase	✓	*	✓
72.	Fundamental Apparent Power per phase	✓	*	✓
73.	Fundamental Power Factor per phase	✓	*	✓
74.	Individual Harmonic Active Power per phase	✓	*	✓
75.	Individual Harmonic Reactive Power per phase	✓	*	✓
76.	Individual Harmonic Apparent Power per phase	✓	*	✓
77.	Distortion Factor of all harmonics on phase voltage	✓	✓	✓
78.	Distortion Factor of all harmonics on phase Current	✓	✓	✓
79.	Power Factor of Individual Harmonic per phase	✓	*	✓
80.	Fundamental voltage RMS per phase	✓	✓	✓
81.	Fundamental current RMS per phase	✓	✓	✓

Ordering Information :

Ordering Information	DM82-	3	8F	75	H	X	0	00000
Product Type	RISH DMCi - Demand Controller							
System Type	3 Phase (On site configurable as 1 / 3 Phase)							
Input voltage	100-500VLL 50/60Hz							
Input Current	CT-1/5A							
Auxiliary Supply	60 - 300V AC/DC							
RS485 Communication	With RS485 communication					R		
	Without RS485 communication					Z		
Accuracy	Class 0.5S							

Order Code Example : DM82-38F75HR000000

RISH DMCi - Demand Controller - 3 Phase, Input 1A/5A, 100-500VLL 50/60Hz, Aux 60-300V AC/DC, with RS485, Accuracy Class 0.5S



Measure



Control



Record



Analyze



Optimize



Specifications may change without prior notice



Measure



Control



Record



Analyze



Optimize

RISHABH INSTRUMENTS LIMITED

Domestic (India): +91 253 2202099 | marketing@rishabh.co.in
International: +91 253 2202004/06/08/99 | global@rishabh.co.in
www.rishabh.co.in